

**ORDINANCE 2022-12**

**AN ORDINANCE OF THE CITY OF BUNNELL, FLORIDA AMENDING THE BUNNELL LAND DEVELOPMENT CODE CHAPTER 22 SITE PLAN REVIEW AND APPROVAL; PROVIDING FOR THE ADOPTION OF AMENDMENTS TO THE MINIMUM STANDARDS OF CONSTRUCTION; PROVIDING FOR CONFLICTING PROVISIONS; PROVIDING FOR SEVERABILITY AND APPLICABILITY; AND PROVIDING AN EFFECTIVE DATE.**

**WHEREAS**, Article VIII, Section 2, *Constitution of the State of Florida*, authorizes the City of Bunnell to exercise any power for municipal purposes except as otherwise provided by law; and

**WHEREAS**, the *Bunnell Land Development Code* provides for procedures for site plan review and approval; and

**WHEREAS**, the City currently has formal minimum standards for construction; and

**WHEREAS**, said procedures are in need of revision; and

**WHEREAS**, Section 163.3174(4)(c), *Florida Statutes*, requires the local planning agency to review proposed land development regulations and amendments, and make recommendations to the governing body as to the consistency of the proposal with the adopted comprehensive plan, or element or portion thereof; and

**WHEREAS**, the Planning, Zoning and Appeals Board reviewed this Ordinance at its April 5, 2022 meeting and recommends adoption; and

**WHEREAS**, the City of Bunnell hereby amends and updates the Bunnell Standard Construction Details and Notes 2022 Edition; and

**WHEREAS**, the Bunnell Standard Construction Details and Notes 2022 Edition are hereby incorporated by reference; and

**WHEREAS**, the City Commission of the City of Bunnell finds it is in the best interest and welfare of the citizens of the City to amend this Ordinance; and

**WHEREAS**, the City of Bunnell has complied with all requirements and procedures of Florida law in processing and advertising this Ordinance; and

**NOW, THEREFORE, BE IT ORDAINED BY THE CITY COMMISSION OF THE CITY OF BUNNELL, FLORIDA AS FOLLOWS:**

**Section 1. Amendment to Chapter 22, Land Development Code.** Chapter 22 Site Plan Review and Approval, the *City of Bunnell Land Development Code* is hereby amended and incorporated by reference as shown in Exhibit A.

**Sec. 22-12. – Minimum Construction Standards.**

(a) Any development or project meeting the requirements of *Section 22-3 Applicability* in which the roadways and/or utilities will be dedicated to the City shall be constructed in accordance with the Bunnell Standard Construction Details and Notes 2022 2014 Edition as amended from time to time ~~or as subsequently amended~~.

**Section 2. Implementing Administrative Actions.**

The City Manager, or designee, is hereby authorized and directed to implement the provisions of this Ordinance and to take any and all necessary administrative actions to include, but not be limited to, the adoption of administrative forms, policies, procedures, processes and rules. All development orders shall be issued in a manner consistent with controlling law and rendered in appealable form with the City Clerk. Denials of development approvals shall be issued in accordance with controlling law to include, but not be limited to, Section 166.033, *Florida Statutes*.

**Section 3. Savings.**

The prior actions of the City of Bunnell relating to the regulation of landscaping, tree protection, tree removal and related matters are hereby ratified and affirmed.

**Section 4. Codification.**

The provisions of this Ordinance, including its recitals, shall become and be made a part of the *Bunnell Land Development Code* and the Sections of this Ordinance may be renumbered or re-lettered to accomplish such intention and the word "Ordinance", or similar words, may be changed to "Section," "Article", or other appropriate word; provided, however, that Sections 2, 3, 4, 5, 6 and 7 shall not be codified. The Code codifier is granted liberal authority to codify the provisions of this Ordinance.

**Section 5. Conflicts.**

All ordinances or parts thereof in conflict with this Ordinance are hereby repealed to the extent of such conflict.

**Section 6. Severability.**

If any section, subsection, sentence, clause, phrase, or portion of this Ordinance, or application hereof, is for any reason held invalid or unconstitutional by any court of competent jurisdiction, such portion or application shall be deemed a separate, distinct, and independent provision and such holding shall not affect the validity of the remaining portions thereof.

**Section 7. Effective Date.** This Ordinance shall take effect immediately upon enactment.

First Reading: approved on this 9<sup>th</sup> day of May 2022.

Second Reading: approved on this 23 day of May 2022.

**CITY COMMISSION, City of Bunnell, Florida.**

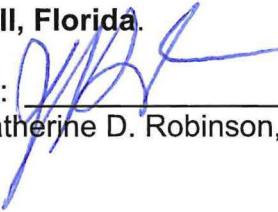
By:  for  
Catherine D. Robinson, Mayor

Approved for form and content by:

  
Vose Law Firm, City Attorney

Attest:

  
Kristen Bates, CMC, City Clerk





**MINIMUM  
ENGINEERING  
STANDARD  
CONSTRUCTION  
DETAILS AND NOTES  
2022**

# STANDARD CONSTRUCTION DETAILS

## TABLE OF CONTENTS

### SECTION I ROADWAY DETAILS

R-1A	ROADWAY CONSTRUCTION NOTES
R-1B	ROADWAY CONSTRUCTION NOTES
R-1C	ROADWAY CONSTRUCTION NOTES
R-2	50' OR 60' R/W ROAD SECTION
R-3	80' R/W ROAD SECTION WITH MEDIAN
R-4	STANDARD CURB CONSTRUCTION
R-5	STANDARD PAVING DETAIL
R-6A	TECHNICAL SPECIFICATIONS FOR TESTING REQUIREMENTS
R-6B	TECHNICAL SPECIFICATIONS FOR TESTING REQUIREMENTS
R-7	SEEDING AND MULCHING
R-8	PAVEMENT CUT AND PATCH

### SECTION II STORM WATER DETAILS

ST-1A	STORM DRAINAGE CONSTRUCTION NOTES
ST-1B	STORM DRAINAGE CONSTRUCTION NOTES
ST-1C	STORM DRAINAGE CONSTRUCTION NOTES
ST-2	CONCRETE SPILLWAY
ST-3	STORM INLET APRON
ST-6	MANHOLE RING AND COVER DETAIL
ST-8	SKIMMER DETAIL

### SECTION III WATER/RECLAIMED WATER SYSTEM DETAILS

W-1A	GENERAL NOTES: WATER
W-1B	GENERAL NOTES: WATER
W-1C	GENERAL NOTES: WATER
W-2	GATE VALVE & VALVE BOX
W-3	WATER LATERAL SERVICE
W-5	PVC & DIP RESTRAINED JOINT TABLE
W-6A	DOUBLE CHECK BACKFLOW PREVENTER (FIRE LINE) 3/4", 1", 1-1/2" OR 2"
W-6B	REDUCED PRESSURE BACKFLOW PREVENTER (POTABLE WATER) 3" OR 4"
W-6C	REDUCED PRESSURE BACKFLOW PREVENTER (POTABLE WATER) 6" OR 8"
W-6D	REDUCED PRESSURE BACKFLOW PREVENTER (POTABLE WATER & IRRIGATION) 3/4", 1", 1 1/2", OR 2"
W-6E	DOUBLE CHECK DETECTOR BACKFLOW PREVENTER (DEDICATED FIRE LINE) 4", 6", 8", 10"
W-7	WATER MAIN INSTALLATION BETWEEN STORM INLET AND SIDEWALK
W-8	FIRE HYDRANT ASSEMBLY
W-9A	WATER MAIN SEPARATION
W-9B	PIPE CROSSING
W-10	AUTOMATIC AIR RELEASE VALVE
W-11	BLOW OFF ASSEMBLY
W-12	WATER METER ASSEMBLY

# STANDARD CONSTRUCTION DETAILS

## TABLE OF CONTENTS

### SECTION IV SANITARY SEWER DETAILS

S-1A	SANITARY SEWER CONSTRUCTION NOTES
S-1B	SANITARY SEWER CONSTRUCTION NOTES
S-1C	SANITARY SEWER CONSTRUCTION NOTES
S-2	OUTSIDE DROP CONNECTION DETAIL
S-3	SHALLOW MANHOLE
S-4	INSIDE DROP CONNECTION (FOR EXISTING MANHOLES)
S-5	RUBBER BOOT AND PRECAST JOINT CONNECTION DETAIL
S-6	SEWER LATERAL DETAIL
S-7	CLEANOUT DETAIL
S-8	SANITARY SEWER CROSSING DETAIL
S-9A	TYPE "A" PRECAST MANHOLE
S-9B	MANHOLE RING & COVER DETAIL
S-10	AUTOMATIC AIR RELEASE VALVE
S-12A	GREASE INTERCEPTOR DETAIL
S-12B	GREASE INTERCEPTOR NOTES
S-13	PRIVATE PUMP-OUT DETAIL

### SECTION V MISCELLANEOUS DETAILS

M-1A	REQUIREMENTS FOR AS-BUILT DRAWINGS (PAVING & DRAINAGE)
M-1B	REQUIREMENTS FOR AS-BUILT DRAWINGS (WATER & SEWER)
M-2	GENERAL CONSTRUCTION NOTES
M-3	SIDEWALK, RAMP, AND DRIVEWAY APRON CONSTRUCTION REQUIREMENTS
M-4	SIDEWALK AND BIKEPATH RAMP
M-5	SINGLE-USE DUMPSTER ENCLOSURE
M-6	DUAL-USE DUMPSTER ENCLOSURE
M-7	RESIDENTIAL DRIVEWAY APRON
M-8	BORE & JACK DETAIL
M-9	PIPE INSTALLATION
M-10	UTILITY PIPE LOCATION MATERIALS
M-11	LOT GRADING PLAN
M-12A	TYPICAL MARKINGS FOR HANDICAP PARKING
M-12B	HANDICAP PARKING SIGN DETAIL
M-13	TEMPORARY GRAVEL CONSTRUCTION ENTRANCE
M-14	EROSION CONTROL - HAY BALES
M-15	EROSION CONTROL - SILT FENCE
M-16	ROAD BARRICADE
M-17	DRIVEWAY CUT REPAIR AT UTILITY CROSSING
M-18	6' CHAIN LINK FENCING DETAIL
M-19	CIP CONSTRUCTION SIGN
M-20	OUTSIDE AGENCY PERMIT CHECK LIST

### SECTION VI SEWER LIFT STATION DETAILS

SLS-1	SEWAGE LIFT STATION DETAILS
SLS-2	PRIVATE COMMERCIAL GRINDER PUMP DETAILS
SLS-3	PRIVATE RESIDENTIAL GRINDER PUMP DETAILS

## ROADWAY CONSTRUCTION NOTES

1. ALL RIGHT OF WAY OTHER THAN ROADWAY AREAS SHALL BE SEEDED AND MULCHED OR SODDED. THE CITY RESERVES THE RIGHT TO REQUIRE SODDING AT ITS DISCRETION.
2. THE FOLLOWING WILL BE THE STANDARD PROTECTION FOR DITCHES UNLESS DRAINAGE CALCULATIONS INDICATE OTHERWISE:

<u>SWALE PROFILE GRADES</u>	<u>PROTECTION REQUIRED</u>
0.2% – 1.0%	SEEDING AND MULCHING
1.0% – 4.0%	SODDING
4.0% AND GREATER	DITCH PAVING

3. ALL FRANCHISE UTILITY CROSSINGS, INCLUDING BUT NOT LIMITED TO FPL, BELLSOUTH AND CABLE SHALL BE INSTALLED PRIOR TO INSTALLATION AND COMPACTION OF THE ROAD SUB BASE. ANY CROSSINGS AFTER INSTALLATION OF THE SUB BASE SHALL BE BY DIRECTIONAL BORE.
- 3A. IF OPEN CUTTING A ROADWAY IS APPROVED BY THE CITY, THE ROAD SHALL BE MILLED AND RESURFACED 25' ON EACH SIDE OF THE REPAIR.
4. THE LIMITS OF STABILIZED SUB BASE SHALL EXTEND TO A DEPTH OF TWELVE INCHES (12") BELOW THE BOTTOM OF THE BASE AND OUTWARD TO TWELVE INCHES (12") BEYOND THE CURB.
5. THE STABILIZING MATERIAL, IF REQUIRED, SHOULD BE A HIGH BEARING VALUE SOIL, SAND-CLAY, LIMEROCK, RECYCLED CONCRETE, SHELL OR OTHER MATERIAL AS APPROVED BY THE CITY AND A LICENSED SOILS ENGINEER.
6. THE SUB BASE SHALL BE STABILIZED NOT LESS THAN FORTY (40) LIMEROCK BEARING RATIO (LBR). A COMPACTION OF NO LESS THAN NINETY-EIGHT (98%) PERCENT DENSITY BASED ON AASHTO T-180 SHALL BE REQUIRED.
7. TESTS FOR SUB BASE BEARING CAPACITY AND COMPACTION SHALL BE DONE AT A MINIMUM OF EVERY 300 FEET AND SHALL BE STAGGERED TO THE LEFT, RIGHT AND AT CENTER LINE OF THE ROADWAY.
8. BASES FOR ALL STREETS SHALL HAVE A MINIMUM SIX INCH (6") DEPTH. PRIMING AND SANDING SHALL BE REQUIRED AS SOON AS BEARING CAPACITY AND COMPACTION HAS BEEN ACHIEVED.
9. RECYCLED CONCRETE OR LIMEROCK BASES SHALL BE COMPACTED TO (98%) MAXIMUM DENSITY BASED ON AASHTO T-180 MODIFIED PROCTOR TEST.
10. MATERIAL DELIVERY TICKETS SHALL BE PROVIDED TO THE CITY AT THE TIME OF PLACEMENT.
11. TESTING OF THE IN-PLACE BASE SHALL BE DONE AT INTERVALS EQUIVALENT TO SUB BASE TESTING AND SHALL CONSIST OF, AS A MINIMUM, MOISTURE CONTENT AND COMPACTION TEST.



### STANDARD CONSTRUCTION DETAIL ROADWAY CONSTRUCTION NOTES

INDEX

R-1A

March 2022

12. DESIGN MIXES SHALL BE SUBMITTED TO THE CITY FOR THEIR APPROVAL NO LESS THAN THREE (3) WORKING DAYS PRIOR TO ANY ROADWAY CONSTRUCTION.
13. ASPHALT SPECIFICATIONS SHALL BE SUBMITTED BY THE DESIGN ENGINEER WITH FINAL PLANS TO THE CITY. FLORIDA STATE CERTIFIED BATCH PLANTS MUST THEN CERTIFY THAT THESE APPROVED SPECIFICATIONS HAVE BEEN MET.
14. EXTRACTION AND GRADATION TESTS ON ASPHALT MIXES SHALL BE PROVIDED TO THE CITY TO INSURE THAT DESIGN MIXES MEET THE CITY STANDARD SPECIFICATIONS.
15. THE ROADWAY CROWN SHALL HAVE A STANDARD ONE QUARTER INCH (1/4") PER FOOT (2%) SLOPE.
16. ALL ROADWAYS WITH CURB AND GUTTER SECTIONS SHALL HAVE AS A STANDARD A MINIMUM LONGITUDINAL SLOPE OF 0.30%.
17. THE FINISHED PAVEMENT EDGE SHALL BE WITHIN ONE QUARTER INCH (1/4") OF THE ADJACENT CONCRETE CURB.
18. IF PROVIDED, CONCRETE CURBS IN NEW SUBDIVISIONS (ON BOTH SIDES OF ALL STREETS) TO BE CONSTRUCTED WITH 3000 PSI CONCRETE AT 28 DAYS.
19. CONCRETE CURBS SHALL BE SAW CUT TO A DEPTH EQUAL TO 1/4 OF CURB THICKNESS AT INTERVALS OF TEN FEET (10') WITH EXPANSION JOINTS AT STREET INTERSECTIONS, STRUCTURES AND ALONG CURVES AT SIXTY FEET (60') INTERVALS. ALL EXPANSION JOINT MATERIAL IS REQUIRED TO BE INSTALLED THROUGH THE ENTIRE DEPTH OF THE CONCRETE CURB.
20. A "V" SHALL BE CUT IN THE CURB TO MARK THE LOCATION OF WATER DISTRIBUTION SYSTEM VALVE.
21. AN "↑" SHALL BE CUT INTO THE CURB TO MARK THE LOCATION OF ALL VALVES OTHER THAN WATER DISTRIBUTION VALVES.
22. AN "S" SHALL BE CUT IN THE CURB TO MARK THE LOCATION OF ALL SEWER SERVICES.
23. A "⊥" SHALL BE CUT IN THE CURB TO MARK THE LOCATION OF ALL RECLAIMED WATER SERVICES.
24. A "W" SHALL BE CUT IN THE CURB TO MARK THE LOCATION OF ALL WATER SERVICES.



STANDARD CONSTRUCTION DETAIL  
ROADWAY CONSTRUCTION NOTES

INDEX

R-1B

March 2022



25. THREE (3) CONCRETE CYLINDERS SHALL BE TAKEN AND TESTED FOR EVERY THREE HUNDRED (300) FEET OF ROADWAY CONSTRUCTED. TEST RESULTS SHALL THEN BE PROVIDED TO THE CITY AS THEY BECOME AVAILABLE.
26. THE DEVELOPER SHALL PROVIDE ALL REQUIRED PAVEMENT MARKINGS ON ALL ROADWAYS PER CITY, COUNTY AND STATE REQUIREMENTS. CENTERLINE STRIPES SHALL BE PROVIDED ON EXTENSIONS OF CITY COLLECTOR OR ARTERIAL ROADS, COUNTY ROADS AND STATE HIGHWAYS ONLY.
27. STOP BARS WITHIN STATE, COUNTY, OR CITY RIGHT-OF-WAY SHALL BE THERMOPLASTIC AND MEET REQUIREMENTS SET FORTH IN THE FDOT STANDARD SPECIFICATIONS FOR ROAD AND BRIDGE CONSTRUCTION CURRENT EDITION, WITH THE EXCEPTION THAT TRAFFIC PAINT MAY BE UTILIZED ON CITY RIGHT-OF-WAY.
28. ALL TRAFFIC CONTROL DEVICES PLACED AT INTERSECTIONS, PRIVATE STREETS, PUBLIC STREETS, COUNTY ROADS AND STATE HIGHWAYS WITHIN THE CITY LIMITS SHALL BE INSTALLED ACCORDING TO THE MANUAL ON UNIFORM TRAFFIC CONTROL DEVICES, LATEST EDITION.
29. THE DEVELOPER IS RESPONSIBLE FOR PAYING FEES FOR ALL STREET LIGHTS PRIOR TO ACCEPTANCE OF THE PROJECT BY THE CITY.
30. STANDARD TURNING RADII FOR INTERSECTIONS:
 

2-LANE ACCESS OR FEEDER	35'
LOCAL TO COLLECTOR	35'
LOCAL OR COLLECTOR TO ARTERIAL	40'
ARTERIAL TO ARTERIAL	50'
31. CITY INSPECTOR SHALL BE PRESENT DURING PAVING OF ALL PUBLIC AND PRIVATE ROADS.
32. CONSTRUCTION METHODS AND DESIGN FOR CONCRETE PAVEMENT SHALL CONFORM TO FDOT STANDARD SPECIFICATION FOR ROAD AND BRIDGE CONSTRUCTION, LATEST EDITION.
33. ALL CONTRACTORS THAT ARE PERFORMING THE CONSTRUCTION OF PUBLIC IMPROVEMENTS (WATER MAIN, SANITARY SEWER MAIN, RECLAIMED WATER MAIN, STORM WATER PIPES AND INLETS AND ALSO CONSTRUCTION OF ROADWAYS) SHALL BE CERTIFIED WITH THE FLORIDA STATE DEPARTMENT OF BUSINESS AND PROFESSIONAL REGULATIONS (DBPR) FOR THE TYPE OF WORK THAT THEY PERFORM. A COPY OF THE VALID LICENSE IS REQUIRED AT PRE CONSTRUCTION MEETING.
34. UTILITY DEPTH (REFERENCED TO FINISHED GRADE):
  - HIGH VOLTAGE UTILITIES SUCH AS POWER (FEEDER, SERVICE AND DROPS) SHALL BE BURIED A MINIMUM OF 30 INCHES IN DEPTH.
  - LOW VOLTAGE UTILITIES SUCH AS PHONE AND CABLE TV SHALL BE BURIED A MINIMUM OF 18 INCHES IN DEPTH FOR FEEDER AND SERVICES. SERVICE DROPS SHALL BE BURIED A MINIMUM OF 18 INCHES IN DEPTH.
  - HIGH VOLTAGE UTILITIES INSTALLED PARALLEL TO PRESSURE MAINS SHALL MAINTAIN A MINIMUM FIVE FOOT SEPARATION.
35. GEOTECHNICAL TESTING REPORTS SIGNED AND SEALED BY A PROFESSIONAL ENGINEER SHALL BE SUBMITTED TO THE CITY PRIOR TO FINAL SIGN OFF. REPORTS SHALL CLEARLY LABEL PROJECT NAME AND PHASE.



STANDARD CONSTRUCTION DETAIL  
ROADWAY CONSTRUCTION NOTES

INDEX

R-1C

March 2022

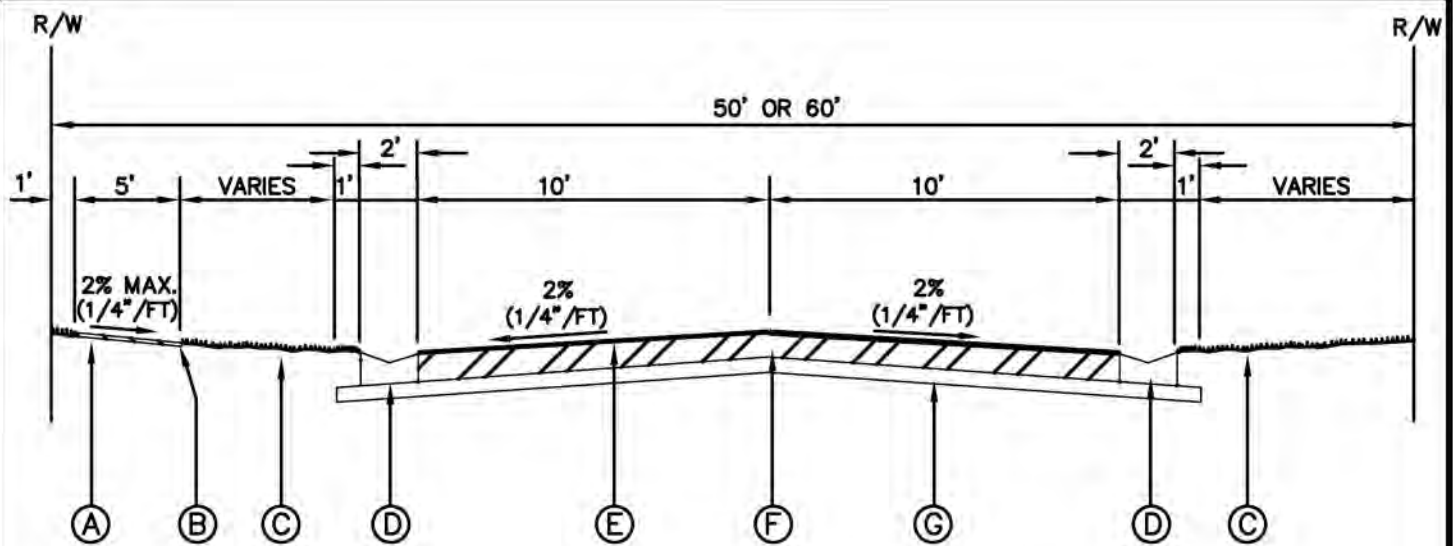

- (A) 5'-0" WIDE CONCRETE SIDEWALK  
4" THICK, 3000 P.S.I.  
6" THICK AT DRIVEWAY
- (B) MAX 6" ABOVE CENTERLINE ROAD GRADE  
MIN. EQUAL TO CENTERLINE ROAD GRADE (PER INDEX M-3(3))
- (C) SOD or SEED AND MULCH PER F.D.O.T. STANDARD SPECIFICATION SECTION 570. 1' SOD STRIP REQUIRED ADJACENT TO CURB AND AROUND DRAINAGE STRUCTURES.
- (D) CONCRETE MIAMI CURB, 3000 P.S.I. OR 6-INCH RIBBON CURB OR 6-INCH EXTENDED STABILIZED BASE.
- (E) ASPHALT PAVEMENT:  
1-1/2" ASPHALT BITUMINOUS CONCRETE TYPE SP-9.5 OR SP-12.5; MINIMUM MARSHALL FIELD STABILITY 1500.
- (F) BASE:  
6" LIMEROCK (LBR 100) COMPACTED TO 98% DENSITY BASED ON AASHTO T-180 MODIFIED PROCTOR TEST.  
OR  
6" CRUSHED CONCRETE (LBR 100) COMPACTED TO 98% DENSITY BASED ON AASHTO T-180 MODIFIED PROCTOR TEST.
- (G) SUB BASE:  
12" SUB BASE COMPACTED TO 98% DENSITY BASED ON AASHTO T-180 MODIFIED PROCTOR TEST WITH MINIMUM LBR 40.

**NOTE TO ENGINEER:**

ENGINEER TO SELECT  
BASE OPTION

**NOTE:**

A REPRESENTATIVE OF A CERTIFIED SOIL LABORATORY SHALL BE PRESENT DURING ALL CONSTRUCTION PHASES TO PERFORM ROADWAY COMPACTION AND DENSITY TESTING AS REQUIRED - SEE INDEX R-6(A/B).



STANDARD CONSTRUCTION DETAIL  
50' OR 60' R/W/ ROAD SECTION  
NTS

INDEX

R-2

March 2022

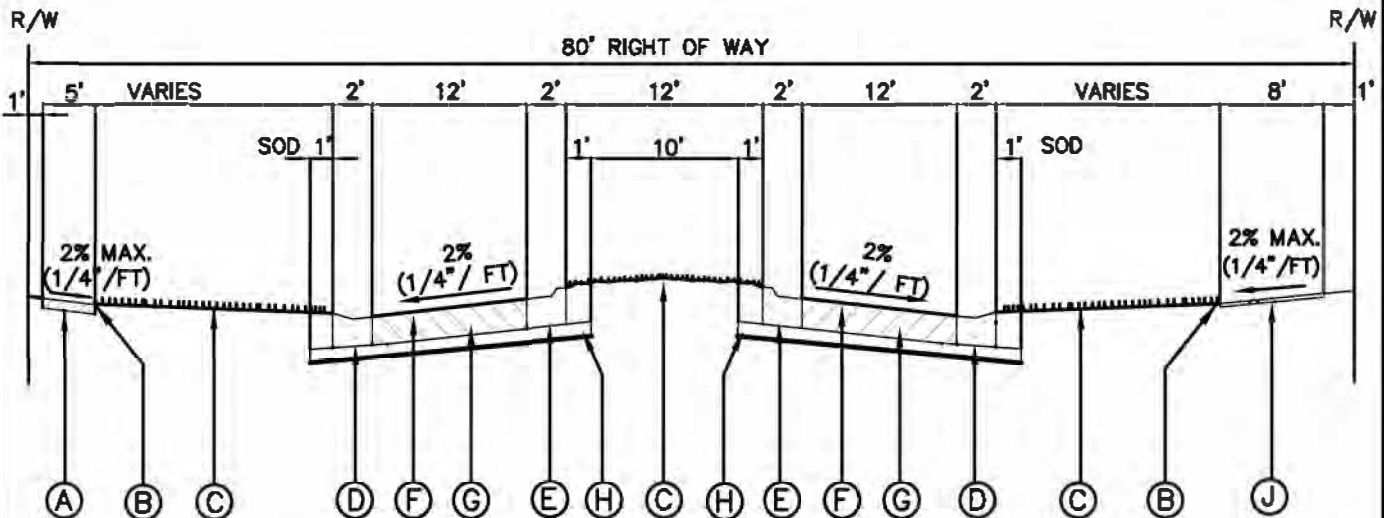

- (A) 5'-0" WIDE CONCRETE SIDEWALK  
4" THICK, 3000 P.S.I.  
6" THICK AT DRIVEWAY
- (B) 6" MAX. ABOVE CENTERLINE ROAD GRADE  
MIN. EQUAL TO CENTERLINE ROAD GRADE (PER INDEX M-3(3))
- (C) SOD or SEED AND MULCH PER F.D.O.T. STANDARD SPECIFICATION SECTION 570.  
1' SOD STRIP REQUIRED ADJACENT TO CURB AND AROUND DRAINAGE STRUCTURES.
- (D) CONCRETE MIAMI CURB, 2500 P.S.I.
- (E) FDOT TYPE-E CONCRETE CURB, 2500 P.S.I., SLOPED TO DRAIN WATER  
FROM GUTTER TO ASPHALT PAVEMENT
- (F) ASPHALT PAVEMENT: 1-1/2" ASPHALT BITUMINOUS CONCRETE TYPE SP-9.5 OR  
SP-12.5; MINIMUM MARSHALL FIELD STABILITY 1500.
- (G) BASE:  
8" LIMEROCK (LBR 100) COMPACTED TO 98% DENSITY  
BASED ON AASHTO T-180 MODIFIED PROCTOR TEST.  
OR  
8" CRUSHED CONCRETE (LBR 100) COMPACTED TO 98% DENSITY  
BASED ON AASHTO T-180 MODIFIED PROCTOR TEST.
- (H) SUB BASE:  
12" SUB BASE COMPACTED TO 98% DENSITY BASED ON AASHTO T-180  
MODIFIED PROCTOR TEST WITH MINIMUM LBR 40.
- (J) 8'-0" WIDE CONCRETE BIKEPATH  
4" THICK, 3000 P.S.I.  
6" THICK AT DRIVEWAY

**NOTE TO ENGINEER:**

ENGINEER TO SELECT  
BASE OPTION

**NOTE:**  
A REPRESENTATIVE OF A CERTIFIED SOIL LABORATORY SHALL BE PRESENT  
DURING ALL CONSTRUCTION PHASES TO PERFORM ROADWAY COMPACTION  
AND DENSITY TESTING AS REQUIRED. SEE INDEX R-6(A/B).



STANDARD CONSTRUCTION DETAIL  
80' R/W ROAD SECTION WITH MEDIAN  
NTS

INDEX

R-3

March 2022

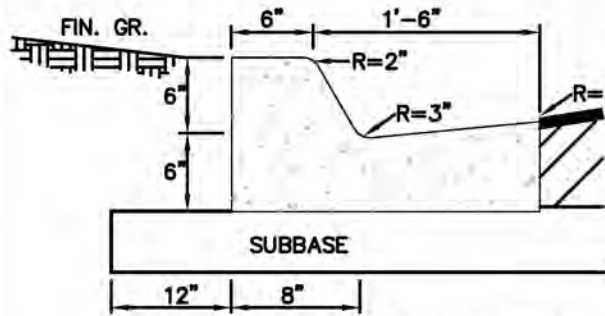

F.D.O.T. TYPE "F" CURB

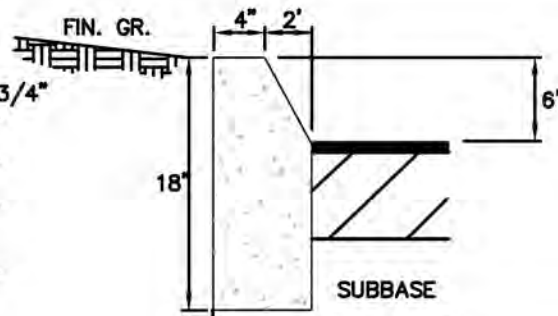

HEADER CURB

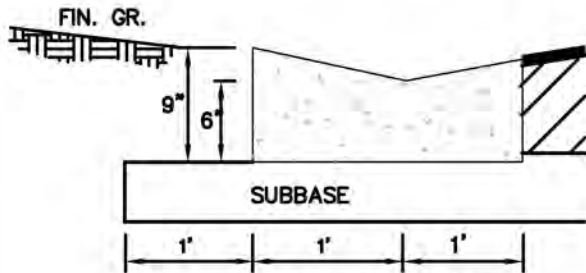

MIAMI CURB

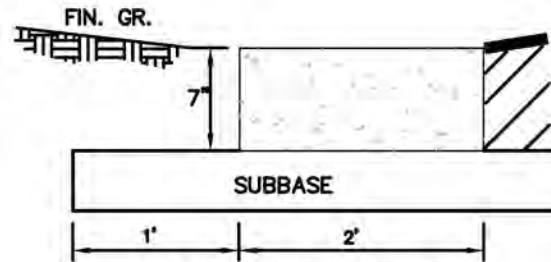

ENVIRONMENTAL CURB

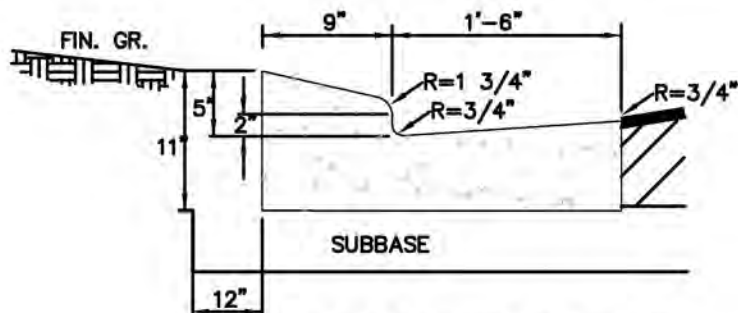

F.D.O.T. TYPE "E" CURB

NOTES:

1. ALL CURBS TO BE CONSTRUCTED OF 28 DAY, 2500 P.S.I. CONCRETE
2. 1/2" PRE-MOLDED EXPANSION JOINT REQUIRED EVERY 500', CONSTRUCTION JOINT REQUIRED EVERY 10' MAXIMUM (4' MINIMUM).
3. 1/2" PRE-MOLDED EXPANSION JOINT REQUIRED AT EACH SIDE OF ALL STORM INLET STRUCTURES AND AT ALL RADIUS POINTS.
4. 12" SUBBASE TO BE COMPACTED AND TESTED TO 98% DENSITY WITH MINIMUM L.B.R. 40 BASED ON AASHTO T-180 MODIFIED PROCTOR TEST.
5. EXPANSION JOINT MATERIAL MUST COVER THE ENTIRE CROSS SECTION OF CURB.
6. ALL EXPOSED CORNERS TO BE ROUNDED AT 3/4" MIN. RADIUS.



STANDARD CONSTRUCTION DETAIL  
STANDARD CURB CONSTRUCTION  
NTS

INDEX

R-4

March 2022

6" LIMEROCK BASE (LBR 100) COMPACTED TO 98%  
MAXIMUM DENSITY (AASHTO T-180)

1 1/2" FDOT TYPE SP-9.5 OR SP-12.5  
ASPHALTIC CONCRETE. 3/4" TO BE  
PLACED DURING INITIAL CONSTRUCTION,  
THEN 3/4" TO BE INSTALLED AFTER THE  
COMPLETION OF THE BUILD-OUT PHASE.

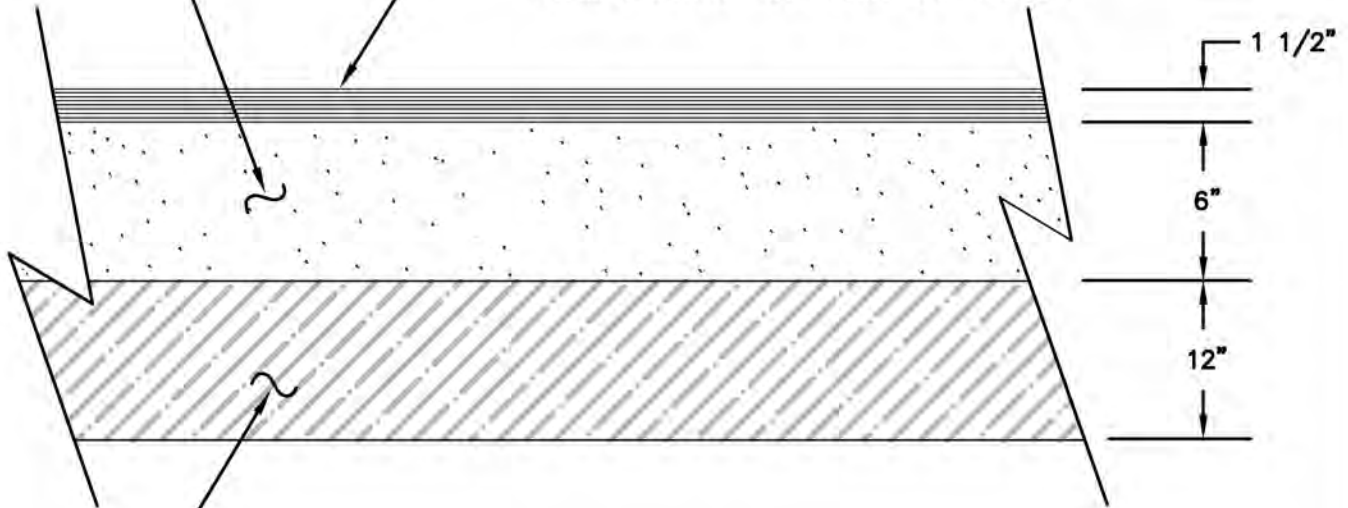

STABILIZE SUB BASE 12" DEEP 75 P.S.I. FBV (LBR 40)  
COMPACTED TO 98% MAXIMUM DENSITY (AASHTO T-180)



STANDARD CONSTRUCTION DETAIL  
STANDARD PAVING DETAIL  
NTS

INDEX

R-5

March 2022

## ROADWAY COMPACTION AND DENSITY TESTING REQUIREMENTS

ITEM	TEST	FREQUENCY	STANDARD	TEST METHOD
ROADWAY SUBBASE (BOTTOM OF SUBBASE DOWN 1 FOOT)	IN-PLACE DENSITY	ONE (1) TEST/300 LF	95% MODIFIED PROCTOR (ASTM D-1557 OR AASHTO T-180)	ASTM D-2937 D-2922 D-1556
STABILIZED SUBBASE	IN-PLACE DENSITY	ONE (1) TEST/300 LF	95% MODIFIED PROCTOR (ASTM D-1557 OR AASHTO T-180)	ASTM D-2937 D-2922 D-1556
STABILIZED SUBBASE	FLORIDA BEARING VALUE (FBV)	ONE (1) TEST/300 LF	FBV = 75	
STABILIZED SUBBASE	LIMEROCK BEARING RATIO (LBR)	ONE (1) TEST/SOIL TYPE	LBR = 40	
LIMEROCK BASE	IN-PLACE DENSITY	ONE (1) TEST/300 LF	98% MODIFIED PROCTOR (ASTM D-1557 OR AASHTO T-180)	ASTM D-2937 D-2922 D-1556
LIMEROCK BASE	LIMEROCK BEARING RATIO (LBR)	PROVIDE CERTIFICATE FROM PLANT	LBR 100	FM 5-515
CRUSHED CONCRETE BASE	IN-PLACE DENSITY	ONE (1) TEST/300 LF	98% MODIFIED PROCTOR (ASTM D-1557 OR AASHTO T-180)	ASTM D-2937 D-1556
CRUSHED CONCRETE BASE	LIMEROCK BEARING RATIO (LBR)	(1) PER VISIBLE CHANGE IN MATERIAL BLEND	LBR 100	
ASPHALT	EXTRACTION AND GRADATION	(1) PER DAY PER MIX	PER MIX DESIGN	D-2922
ASPHALT	THICKNESS AND DENSITY	(1) PER 300 LF ROADWAY	PER MIX DESIGN AND JOB SPECS	CORING OR NUCLEAR (DENSITY ONLY)
SOIL OPTIMUM MOISTURE/DENSITY	PROCTOR TEST	(1) PER SOIL OR BASE TYPE		ASTM D-1557 (MODIFIED) ASTM D-558 (STANDARD) AASHTO T-180 (MODIFIED) AASHTO T-99 (STANDARD)
CURB SUBBASE	IN-PLACE DENSITY	ONE (1) TEST/300 LF	98% MODIFIED PROCTOR (ASTM D-1557 OR AASHTO T-180)	
CURB SUBBASE (LBR)	LIMEROCK BEARING RATIO (LBR)	(1) TEST/SOIL CHANGE	LBR 40	



### STANDARD CONSTRUCTION DETAIL TECHNICAL SPECIFICATIONS FOR TESTING REQUIREMENTS

INDEX

R-6A

March 2022

## PIPED UTILITY INSTALLATION REQUIREMENTS

ITEM	TEST	FREQUENCY	STANDARD	TEST METHOD
PIPE TRENCH SUBBASE (IF SPECIFIED)	IN-PLACE DENSITY	ONE (1) TEST/300 LF	98% MODIFIED PROCTOR	ASTM D-2937 D-2922 D-1556
PIPED BACKFILL IN PAVED AREAS & ANY OTHER CONDITION NOT SPECIFICALLY MENTIONED	IN-PLACE DENSITY	ONE (1) TEST/300 LF PER ONE (1) FOOT VERTICAL LIFT OF FILL	98% MODIFIED PROCTOR	ASTM D-2937 D-2922 D-1556
PIPED BACKFILL IN GREEN AREAS	IN-PLACE DENSITY	ONE (1) TEST/300 LF PER ONE (1) FOOT VERTICAL LIFT OF FILL	90% MODIFIED PROCTOR	ASTM D-2937 D-2922 D-1556
SOIL OPTIMUM MOISTURE/DENSITY	PROCTOR TEST	ONE (1) PER SOIL OR BASE TYPE		ASTM D-2937 (MODIFIED) ASTM D-558 (STANDARD) AASHTO T-180 (MODIFIED) AASHTO T-99 (STD.)



STANDARD CONSTRUCTION DETAIL  
TECHNICAL SPECIFICATIONS FOR  
TESTING REQUIREMENTS

INDEX

R-6B

March 2022

A. SCOPE OF WORK – THE WORK IN THIS SECTION CONSISTS OF FURNISHING AND COMPLETELY INSTALLING SEED AND MULCH OVER THE LIMITS CALLED FOR ON THE CONSTRUCTION DRAWINGS. WATER AS NEEDED TO ESTABLISH AND MAINTAIN GRASS UNTIL ACCEPTED BY THE CITY.

B. MATERIALS – GRASS SEED SHALL BE A MIXTURE OF:  
THE CONSTRUCTION DRAWINGS.

PENSACOLA BAHIA (50% SCARIFIED SEED)	80 LBS/ACRE
HULLED BERMUDA	20 LBS/ACRE
BROWN TOP MILLET	30 LBS/ACRE

IN THE FALL AND WINTER MONTHS (OCT. THRU FEB.) AND WITH THE APPROVAL OF THE CITY, ANNUAL RYE GRASS SHALL BE SUBSTITUTED IN EQUAL AMOUNTS FOR THE BROWN TOP MILLET. SEED SHALL BE PREMIXED BY A SEED COMPANY TO THE PROPORTIONS DESCRIBED ABOVE, WITH CERTIFICATION FROM THE SUPPLIER PROVIDED TO THE CITY, PRIOR TO USE. MULCH USED SHALL BE STRAW OR HAY CONSISTING OF OATS, RYE OR WHEAT STRAW OF PANGOLA, PEANUT, COASTAL BERMUDA OR BAHIA GRASS HAY. MULCH SHALL BE FREE FROM UNDESIRABLE WEED AND OTHER UNDESIRABLE GRASS.

C. METHODS – GRASSING SHALL BE DONE IMMEDIATELY UPON COMPLETION OF THE FINE GRADING OPERATION. HOWEVER, NO SEEDING SHALL BE DONE WHEN THE GROUND IS FROZEN OR UNDULY WET. THE RATE OF SPREAD FOR THE SEED MATERIAL SHALL BE ONE HUNDRED AND THIRTY (130) POUNDS PER ACRE, AS STATED ABOVE. APPROXIMATELY TWO INCHES (2”), LOOSE THICKNESS, OF MULCH MATERIAL SHALL BE APPLIED INFORMALLY OVER THE GRASSED AREAS (APPROXIMATELY 1 1/2 BALES PER 1000 SQUARE FEET). THE MULCH MATERIAL SHALL BE CUT INTO THE SOIL WITH A DISC HARROW OR OTHERWISE ANCHORED DOWN.

D. FERTILIZER –  
1. RESERVED

2. THE FERTILIZER SHALL BE A COMMERCIAL GRANULAR TYPE WITH A CHEMICAL DESIGNATION AS RECOMMENDED IN THE SOILS ANALYSIS REPORT.

3. THE NUMERICAL DESIGNATIONS FOR FERTILIZER INDICATE THE MINIMUM PERCENTAGES (RESPECTIVELY) OF (1) TOTAL NITROGEN, (2) AVAILABLE PHOSPHORIC ACID AND (3) WATER SOLUBLE POTASH CONTAINED IN THE FERTILIZER.

a) AT LEAST 50 PERCENT (50%) OF THE PHOSPHORIC ACID SHALL BE FROM A NORMAL SUPER PHOSPHATE OR AN EQUIVALENT SOURCE WHICH WILL PROVIDE A MINIMUM OF TWO UNITS OF SULFUR.

b) THE AMOUNT OF SULFUR SHALL BE INDICATED ON THE QUANTITATIVE ANALYSIS CARD ATTACHED TO EACH BAG OR CONTAINER.

4. COMMERCIAL FERTILIZERS SHALL COMPLY WITH THE STATE FERTILIZER LAWS.

5. FERTILIZER MAY, AT THE DISCRETION OF THE ENGINEER/ARCHITECT, UPON THE PRESENTATION BY THE MANUFACTURE OF SATISFACTORY FACTORY EVIDENCE OF ITS FEASIBILITY, BE APPLIED IN LIQUID FORM.



STANDARD CONSTRUCTION DETAIL  
SEEDING AND MULCHING

INDEX

R-7

March 2022



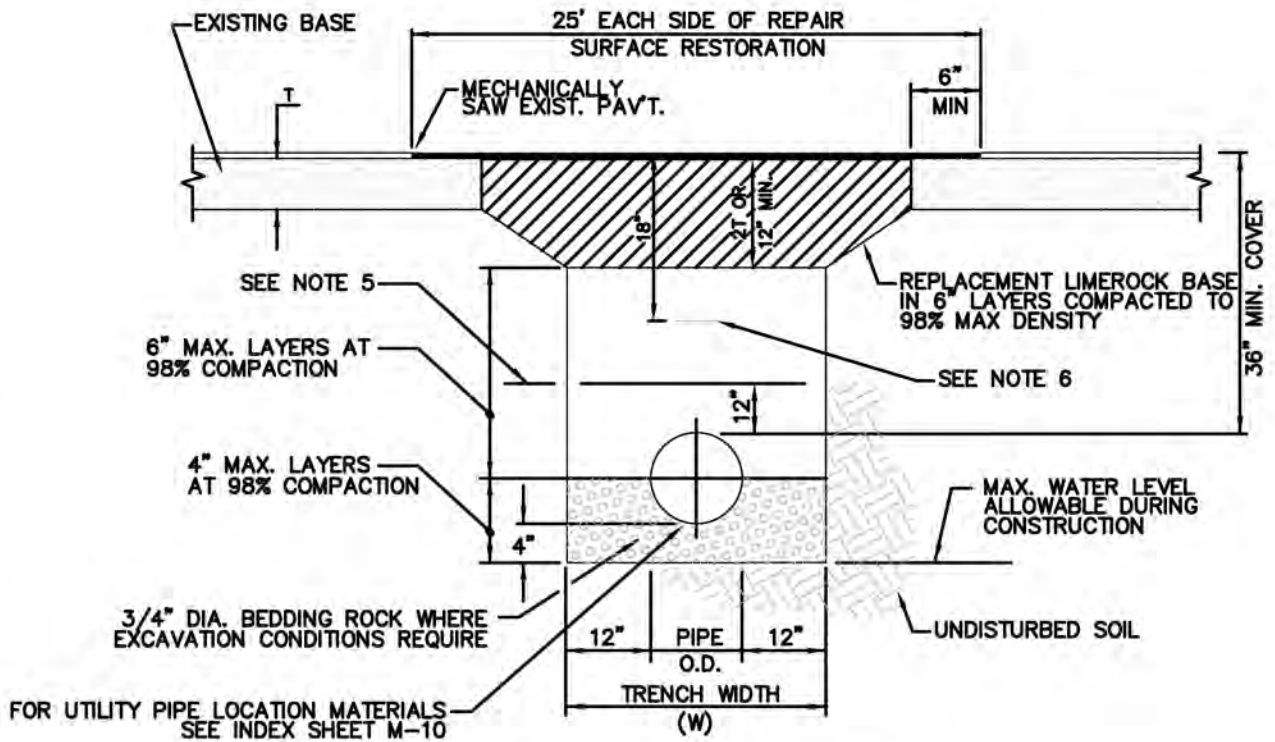

### PAVEMENT CUT AND PATCH DETAIL

#### NOTES:

1. WHERE SOIL CONDITIONS CAN NOT BE MAINTAINED AS SHOWN ABOVE, PROVIDE APPROVED METHOD OF CONSTRUCTION.
2. SHEETING WILL BE REQUIRED AS DETERMINED IN THE FIELD.
3. NEW SURFACING MATERIALS SHALL BE CONSISTENT WITH EXISTING AND SHALL HAVE LAPPED & FEATHERED JOINTS (1 1/2" MIN. THK.)
4. COMPACTION PERCENTAGES SHOWN REFER TO A.A.S.H.T.O. T-180. PROVIDE COMPACTION TEST REPORTS TO CITY INSPECTOR.
5. MECHANICAL COMPACTION NOT ALLOWED BELOW THIS LEVEL.
6. INSTALL METALLIC TAPE OVER FULL LENGTH OF PIPE.
7. EIGHT INCHES (8") OF HIGH EARLY-STRENGTH CONCRETE MAY BE SUBSTITUTED FOR LIMEROCK UPON APPROVAL BY CITY.



STANDARD CONSTRUCTION DETAIL  
PAVEMENT CUT AND PATCH  
NTS

INDEX

R-8

March 2022

1. CONSTRUCTION STANDARDS FOR ALL DRAINAGE SYSTEM COMPONENTS SHALL CONFORM TO THE LATEST EDITION OF THE "FDOT STANDARD SPECIFICATIONS FOR ROAD AND BRIDGE CONSTRUCTION" AND AS SPECIFIED HEREIN.
2. ALL STORMWATER PIPES AND STRUCTURES SHALL BE INSTALLED ON A FIRM FOUNDATION WITH ALL UNSUITABLE MATERIAL (MUCK, ROCK, COQUINA, ETC.) REMOVED AND REPLACED WITH CLEAN GRANULAR MATERIAL.
3. DEWATERING SHALL BE PROVIDED TO KEEP GROUNDWATER ELEVATION A MINIMUM OF 6 INCHES BELOW THE COMPONENT BEING INSTALLED.
4. ALL PIPES AND STRUCTURES SHALL BE PLACED TRUE TO LINES AND GRADES AS DEPICTED ON THE APPROVED PLANS.
5. ALL PIPE JOINTS SHALL BE PROPERLY HONED AND FILTER FABRIC LINED USING A METHOD TO HOLD THE FABRIC IN PLACE DURING BACKFILL.
6. BACKFILL AND COMPACT TO THE SPRING-LINE (CENTER OF PIPE) ELEVATION AND REQUEST CITY INSPECTION AND APPROVAL BEFORE CONTINUING.
7. ALL WORK COVERED WITHOUT CITY INSPECTION WILL BE REQUIRED TO BE EXCAVATED AND INSPECTED AT THE CONTRACTOR'S EXPENSE.
8. TRENCHES SHALL BE BACKFILLED AND COMPACTED WITH CLEAN GRANULAR MATERIAL IN MAX 6" LIFTS WITH A MINIMUM COMPACTION OF 98 PERCENT (AASHTO-T180) IN PAVED AREAS AND 98 PERCENT (AASHTO-T180) IN UNPAVED AREAS.
9. IT SHALL BE THE CONTRACTOR'S RESPONSIBILITY TO ENSURE THAT TRENCH COMPACTION TESTS AT POINTS 1' ABOVE THE PIPE AND AT A MAX. 1' VERTICAL INTERVALS TO FINISH GRADE, AT A MAXIMUM SPACING OF 100 FEET, AND TO FURNISH COPIES OF TEST REPORTS PROMPTLY TO THE CITY'S INSPECTOR.
10. ALL STORM SEWER PIPE SHALL BE REINFORCED CONCRETE (RCP), HP PIPE, OR HIGH DENSITY POLYETHYLENE (HDPE) MAY BE USED AS APPROVED BY THE CITY.
11. STORM DRAINAGE PIPES WITHIN PUBLIC RIGHT-OF-WAY SHALL BE A MINIMUM OF TWELVE (12) INCH RCP DIAMETER OR EQUIVALENT.
12. STORM INLETS, MANHOLES, AND CATCH BASINS SHALL BE EITHER POURED IN PLACE OR PRECAST REINFORCED CONCRETE. STRUCTURES SHALL BE REQUIRED AT EACH CHANGE OF PIPE SIZE OR CHANGE IN PIPE DIRECTION.
13. ALL SIDE DRAIN AND CROSS DRAIN MITERED ENDS PLACED WITHIN FDOT RIGHT-OF-WAY SHALL BE CAST-IN-PLACE ONLY. ALL MITERED ENDS SHALL MEET REQUIREMENTS OF THE MOST CURRENT FDOT DESIGN STANDARDS AND FDOT STANDARD SPECIFICATIONS FOR ROAD AND BRIDGE CONSTRUCTION.



## STANDARD CONSTRUCTION DETAIL

### STORM DRAINAGE CONSTRUCTION NOTES

INDEX

ST-1A

March 2022

13A. STORM INLETS SHALL BE SPACED IN SUCH A MANNER AS TO ACCEPT ONE HUNDRED (100) PERCENT OF THE DESIGN STORM RUNOFF.

14. WET DETENTION PONDS SHALL BE EIGHT (8) FEET MINIMUM TO TWELVE (12) FEET MAXIMUM DEPTH BELOW THE DESIGN LOW OR NORMAL WATER STAGE.

15. MAXIMUM DISTANCES BETWEEN INLETS AND/OR JUNCTION BOXES:

<u>PIPES SIZE (INCHES)</u>	<u>LENGTH OF RUN (FEET)</u>
15 OR LESS	150
18	300
24 OR GREATER	400

16. ALL SWALES, DITCHES, AND DRY RETENTION POND SIDE SLOPES SHALL BE NO STEEPER THAT 4:1 (H:V) AND SHALL BE SODDED.

17. ALL RETENTION POND BACKSLOPES SHALL BE NO STEEPER THAN 3:1 (H:V) AND SHALL BE SODDED.

18. NORMAL ROADSIDE SWALES SHALL BE CONSTRUCTED TO A MAXIMUM DEPTH OF 18" BELOW THE OUTSIDE EDGE OF PAVEMENT OR CONCRETE CURB.

19. CONCRETE EROSION CONTROL MUST BE PROVIDED WHERE SWALES OR CULVERTS INTERCEPT DRAINAGE DITCHES.

20. A MINIMUM ONE FOOT (1') FREEBOARD ABOVE THE DESIGN HIGH WATER ELEVATION IS REQUIRED AT ALL POINTS AROUND WET DETENTION PONDS.

21. A MINIMUM OF TWELVE INCHES (12") FREEBOARD ABOVE THE DESIGN HIGH WATER ELEVATION IS REQUIRED AT ALL POINTS AROUND DRY RETENTION PONDS.

22. POND INFLOW SHALL GENERALLY BE CONSTRUCTED WITH REINFORCED CONCRETE AND SHALL BE SUBJECT TO THE APPROVAL OF THE CITY.

23. OUTLET STRUCTURES ARE REQUIRED ON ALL PONDS. ALL OUTLET STRUCTURES SHALL BE PERMANENT CONCRETE OVERFLOW WEIRS OR CONCRETE OUTLET CONTROL STRUCTURES. NO SODDED WEIRS OR OTHER NON-PERMANENT OVERFLOW STRUCTURES SHALL BE ALLOWED.

24. SOIL EROSION CONTROL MEASURES SATISFACTORY TO THE CITY, SHALL BE EMPLOYED DURING CONSTRUCTION AND UPON COMPLETION OF THE POND.

25. THE CITY MAY REQUEST THAT THE DEVELOPER SUBMIT A REPORT BY A QUALIFIED HYDROLOGIST ON THE IMPACT THE POND WILL HAVE ON NEIGHBORING WATER TABLE ELEVATIONS BOTH DURING CONSTRUCTION AND AFTER POND COMPLETION. THE CITY MAY REQUIRE GROUNDWATER MONITORING DURING THE POND EXCAVATION.



## STANDARD CONSTRUCTION DETAIL

STORM DRAINAGE  
CONSTRUCTION NOTES

INDEX

ST-1B

March 2022

26. ADEQUATE MAINTENANCE ACCESS AS APPROVED BY THE CITY SHALL BE PROVIDED AROUND THE ENTIRE PERIMETER OF ALL PONDS AND ASSOCIATED OUTFALLS DISCHARGING INTO AND OUT OF PONDS.
27. IN GENERAL, ALL RETENTION/DETENTION PONDS MUST BE CONSTRUCTED PRIOR TO ANY ROAD, PARKING LOT, OR BUILDING CONSTRUCTION COMMENCING OR AS CURRENT PERMIT CONDITIONS DICTATE.
28. THE CONTRACTOR SHALL BE RESPONSIBLE TO OBTAIN ANY DEWATERING PERMITS THAT MAY BE REQUIRED.
29. CULVERTS CROSSING RIGHT-OF-WAYS SHALL EXTEND FROM RIGHT-OF-WAY LINE TO RIGHT-OF-WAY LINE UNDER THE ROADWAY.
30. ALL STORMWATER DISCHARGE FROM RETENTION/DETENTION PONDS ARE REQUIRED TO BE CHANNLED INTO DEFINED DRAINAGE PATHS TO EXISTING WATER BODIES, WETLANDS, DITCHES, ETC.
31. THE CITY REQUIRES THE DEVELOPER TO TELEWISE ANY AND ALL STORM SEWER PIPE SYSTEMS PRIOR TO ANY FINAL ACCEPTANCE BY THE CITY.
32. ALL STORM SEWER PIPE SYSTEMS SHALL BE TELEVISED IN THE PRESENCE OF THE CITY INSPECTOR AND COPIES OF THE VIDEO AND WRITTEN REPORT SHALL BE SUBMITTED IN DIGITAL FORMAT TO THE INSPECTOR AT LEAST FORTY EIGHT (48) HOURS PRIOR TO REQUESTING FINAL INSPECTIONS. ANY DEFECTS NOTED SHALL BE CORRECTED PRIOR TO ACCEPTANCE BY THE CITY.
33. ALL STORM SEWER PIPES, PRIOR TO ACCEPTANCE BY THE CITY, SHALL BE TELEVISED BY A REPUTABLE COMPANY THAT ENGAGES IN THIS TYPE OF WORK. THE VIDEO SHALL BE IN DIGITAL FORMAT WITH HIGH QUALITY STANDARD RESOLUTION USING A CAMERA WITH SUITABLE LIGHTING TO ALLOW A CLEAR AND FOCUSED PICTURE OF THE ENTIRE INSIDE PIPE CIRCUMFERENCE. THE VIDEO SHALL BE NON-STOP WITH AUDIO DESCRIBING WHAT IS BEING VIEWED. WRITTEN LOGS DESCRIBING THE CONDITION OF THE LINES SHALL ACCOMPANY THE DIGITAL SUBMISSION TO THE CITY.



STANDARD CONSTRUCTION DETAIL  
 STORM DRAINAGE  
 CONSTRUCTION NOTES

INDEX

ST-1C

March 2022

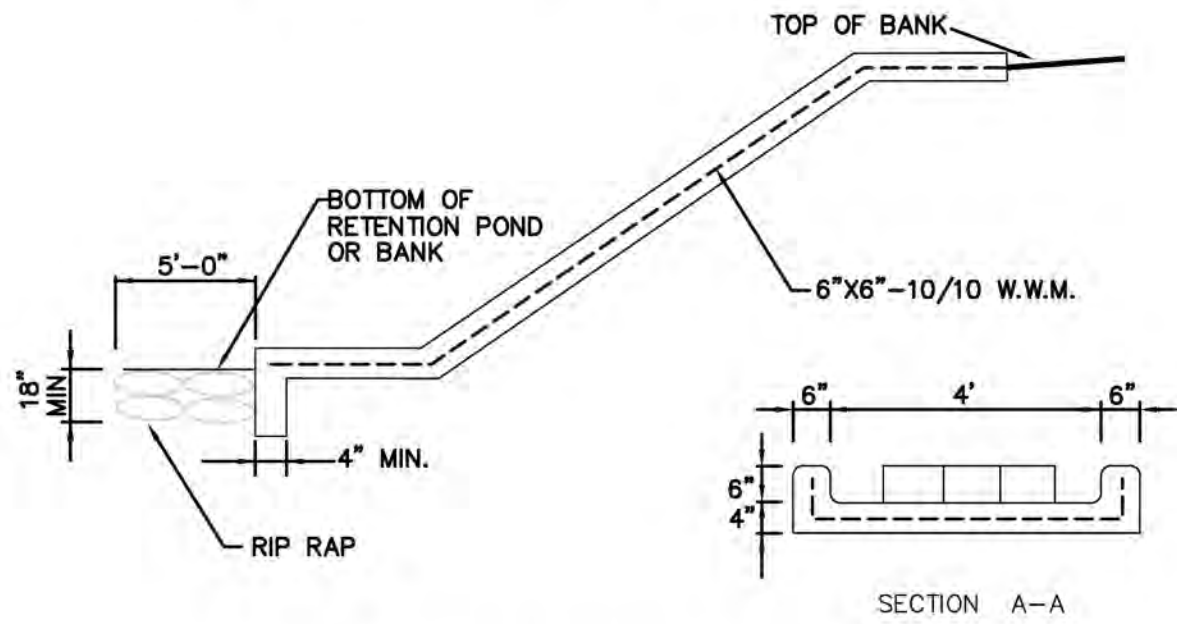
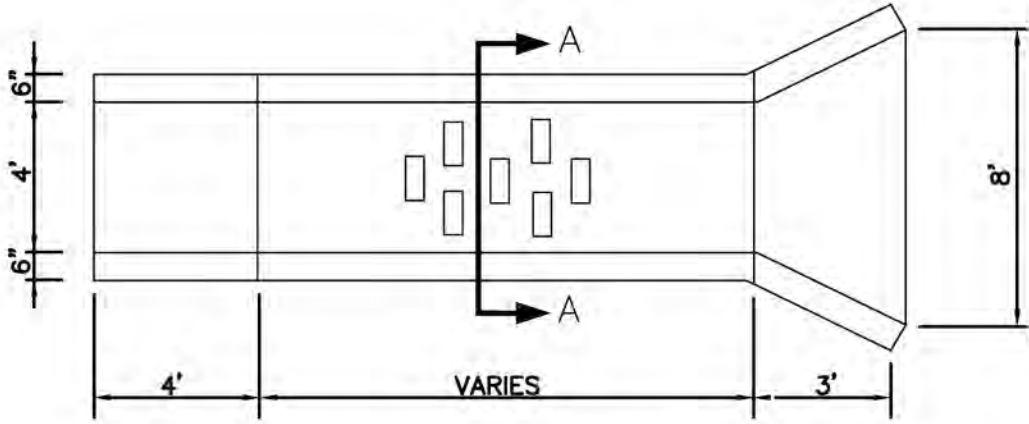

1. CONCRETE SPILLWAY TO BE 28 DAY, 3000 P.S.I., 4" THICK.
2. PLACE SOD AT LEAST 5' AROUND ALL STRUCTURE EDGES ABOVE STANDING WATER.
3. ALL EXPOSED CORNERS TO BE ROUNDED @ 3/4" MINIMUM RADIUS.



STANDARD CONSTRUCTION DETAIL  
CONCRETE SPILLWAY  
NTS.

INDEX
ST-2
March 2022

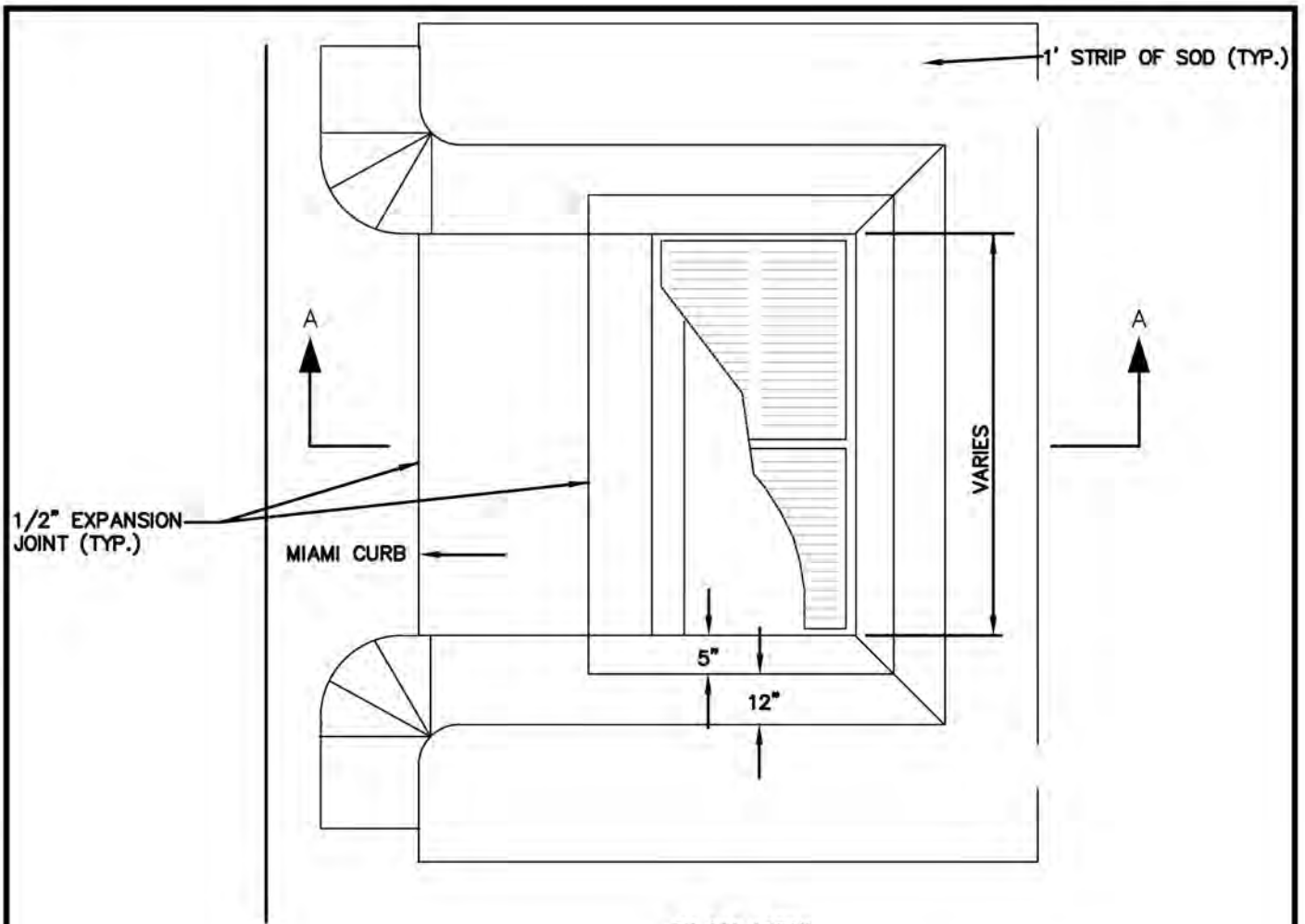

PLAN VIEW

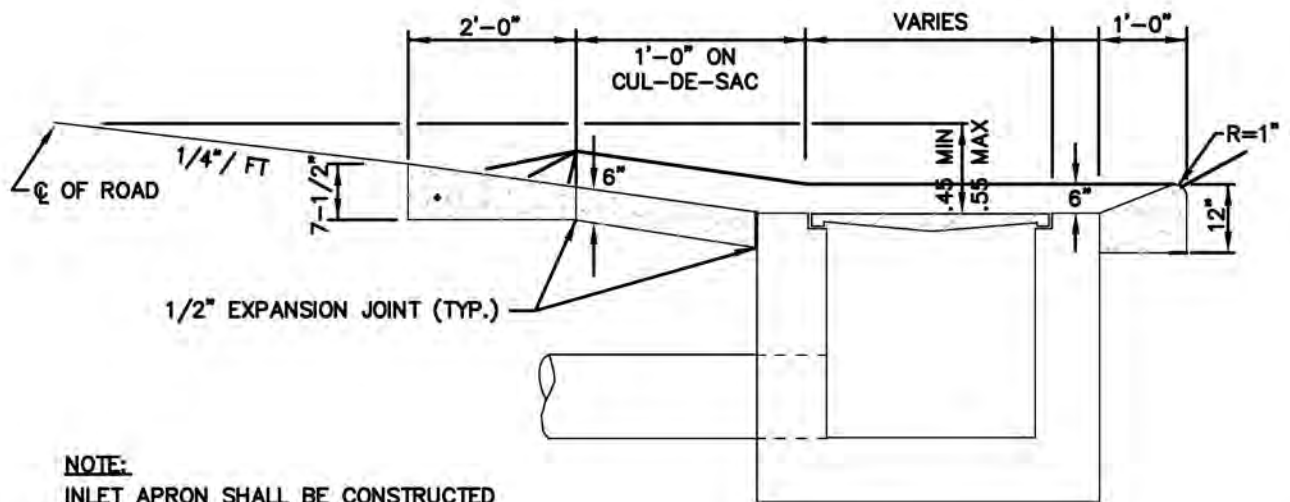

SECTION A-A



STANDARD CONSTRUCTION DETAIL  
STORM INLET APRON  
NTS

INDEX

ST-3

March 2022

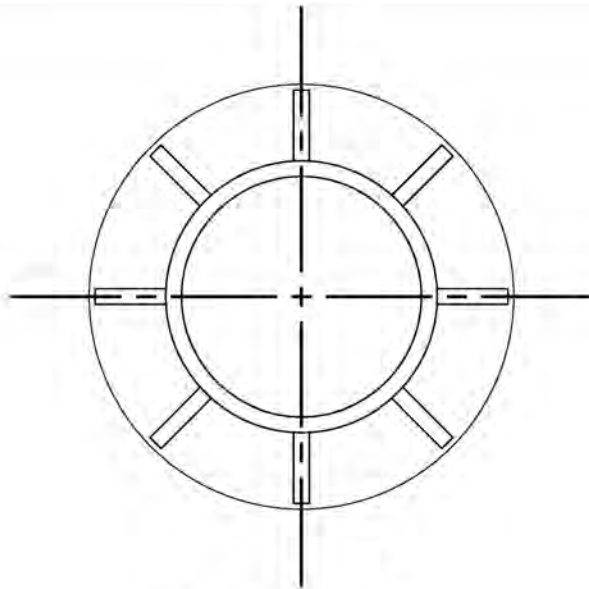

RING TOP VIEW

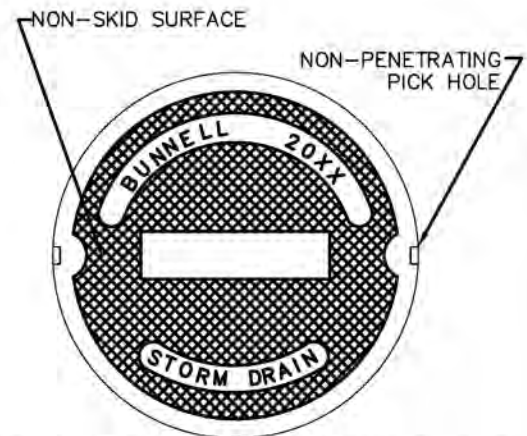

XX = USE CURRENT YEAR OF MANUFACTURE

COVER DETAIL

N.T.S.

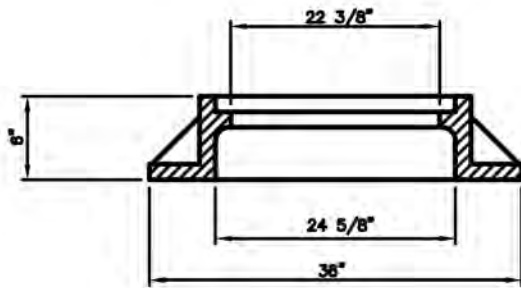

RING SECTION

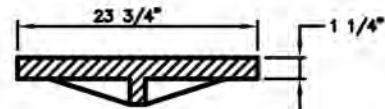

COVER SECTION

NOTE: YEAR STAMP TO MATCH CASTING YEAR

U. S. FOUNDRY 195E OR APPROVED EQUAL

COVER TYPE	LOAD RATING	COVER WEIGHT	TOTAL WEIGHT
E	HEAVY DUTY	130	325

FOR MANHOLES IN FL. D.O.T. R/W OR AS DETERMINED BY THE CITY. THE COVER TYPE SHALL BE - BJ HEAVY DUTY 200 LBS W/ ORS.



STANDARD CONSTRUCTION DETAIL  
MANHOLE RING AND COVER DETAIL  
N.T.S.

INDEX

ST-6

March 2022

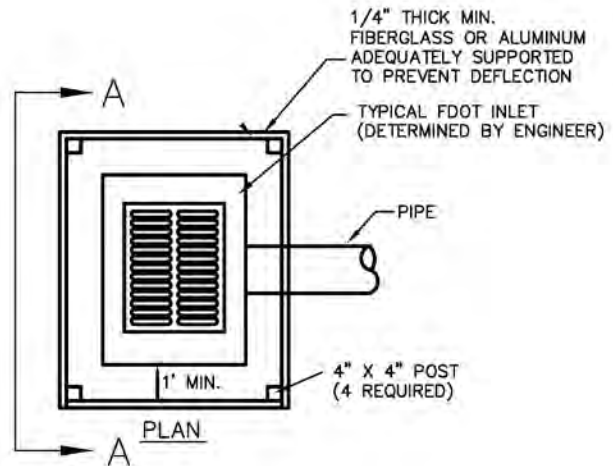
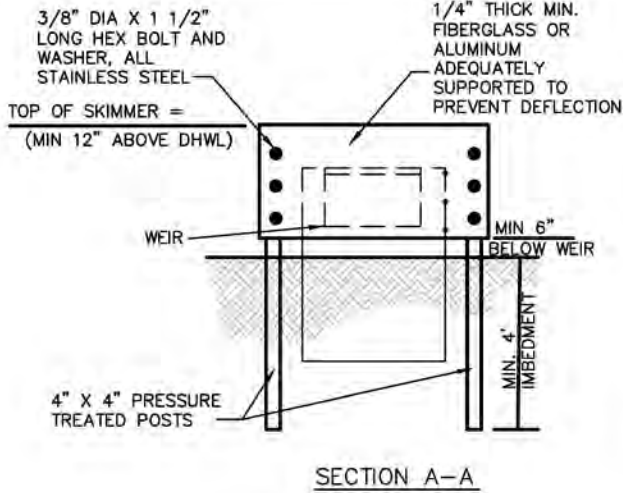

CONTROL STRUCTURE

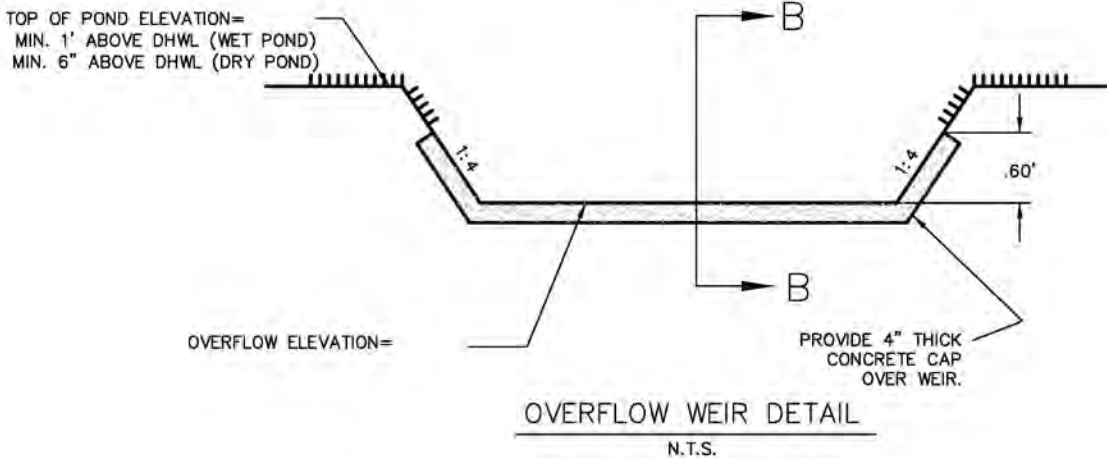
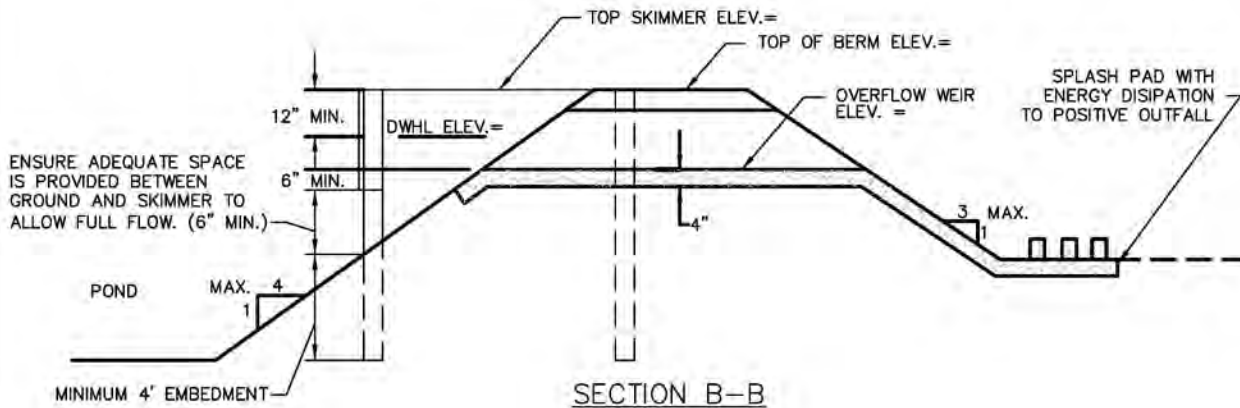

NOTE:  
PROVIDE DESIGN DATA WHERE INDICATED (=)



STANDARD CONSTRUCTION DETAIL

SKIMMER DETAIL  
NTS

INDEX

ST-8

March 2022



GENERAL NOTES  
WATER SYSTEM CONSTRUCTION

1. THE CITY'S PUBLIC UTILITIES DEPARTMENT SHALL BE NOTIFIED PRIOR TO BEGINNING ANY WATER SYSTEM CONSTRUCTION.
2. DEWATERING SHALL BE PROVIDED TO KEEP GROUNDWATER ELEVATION A MINIMUM OF 6 INCHES BELOW WATER MAIN BEING LAID.
3. ALL WATER MAINS SHALL BE LAID ON A FIRM FOUNDATION WITH ALL UNSUITABLE MATERIAL (MUCK, ROCK, COQUINA, ETC.) REMOVED AND REPLACED WITH CLEAN GRANULAR MATERIAL.
4. TRENCHES SHALL BE BACKFILLED WITH CLEAN GRANULAR MATERIAL IN MAX. 1' LIFTS WITH A MINIMUM COMPACTION OF 98 PERCENT (AASHTO-T180) IN PAVED AREAS OR IN UNPAVED AREAS.
5. IT SHALL BE THE CONTRACTOR'S RESPONSIBILITY TO ENSURE THAT TRENCH COMPACTION TESTS BE PROVIDED AT POINTS 1 FOOT ABOVE THE PIPE AND AT 1 FOOT VERTICAL INTERVALS TO FINISH GRADE, AT A MINIMUM SPACING OF EVERY 300 FEET, AND TO FURNISH COPIES OF TEST REPORTS PROMPTLY TO THE CITY UTILITIES DEPARTMENT.
6. METALLIZED PIPE LOCATION TAPE SHALL BE LOCATED 15 INCHES BELOW FINISHED GRADE OR AS SPECIFIED BY MANUFACTURER FOR ALL PVC LINES. MARKER TAPE SHALL BE USED ON ALL DUCTILE IRON PIPE.
7. WATER SERVICES (SINGLE 1" OR DOUBLE 2") SHALL BE POLYETHYLENE TUBING (BLUE IN COLOR) ; POLYBUTYLENE SHALL NOT BE ALLOWED.
8. ALL WATER SERVICE ENDINGS SHALL BE MARKED WITH 4" X 4" LUMBER (PRESSURE TREATED) EXTENDING 4 FEET ABOVE GRADE, WITH WATER SERVICES SECURED 24" ABOVE THE GROUND. WIRE TIES SHALL BE USED TO SECURE THE CURB STOPS TO SUPPORT POSTS.
9. WATER VALVES SHALL BE PLACED AT ALL STREET INTERSECTIONS AND AT MAXIMUM SPACINGS OF 500 FEET.
10. AT ALL WATER MAIN TEES AND CROSSES, VALVES SHALL BE INSTALLED ON ALL LEGS EXCEPT ONE.
11. APPROVED WATER VALVE TYPES ARE THE FOLLOWING:
  - A. STANDARD GATE VALVES LESS THAN 48" DIAMETER RESILIENT SEAT GATE VALVES (AWWA C-509 OR C-515).
  - B. TAPPING VALVES AND MECHANICAL TAPPING SLEEVE SHALL BE STAINLESS STEEL. (AWWA C - 509)



STANDARD CONSTRUCTION DETAIL

GENERAL NOTES  
WATER SYSTEM CONSTRUCTION

INDEX

W-1A

March 2022

GENERAL NOTES  
WATER SYSTEM CONSTRUCTION

12. ALL WATER VALVE BOXES SHALL BE ADJUSTED TO FINISH GRADE AND THE LIDS PAINTED BLUE TO MAKE THEM PLAINLY VISIBLE.
13. WATER VALVES SHALL BE COMPLETELY OPENED BY THE CONTRACTOR UPON FINAL ACCEPTANCE OF NEW WATER SYSTEMS IN THE PRESENCE OF UTILITY DEPARTMENT PERSONNEL.
14. HYDRANTS SHALL BE PLACED AT MAXIMUM SPACINGS IN ACCORDANCE WITH NFPA (LATEST EDITION). SPECIAL EXCEPTIONS MAY BE ALLOWED BY FIRE AUTHORITY HAVING JURISDICTION. ALL WATER MAIN TO WHICH HYDRANTS ARE CONNECTED SHALL BE 6 INCHES MINIMUM.
15. ALL FIRE HYDRANTS SHALL BE CONSTRUCTED TO MAKE THEM EASILY ACCESSIBLE TO FIRE PERSONNEL IN CASE OF FIRE. THE MAIN NOZZLE CONNECTION SHOULD ALWAYS FACE THE STREET AND BE 18-24" ABOVE GRADE.
16. AS STANDARD PRACTICE, WATER MAINS SHALL BE INSTALLED 4 FEET OFF THE BACK OF CURB OR AS APPROVED BY THE CITY.
17. ALL WATER MAINS AND APPURTENANCES SHALL BE NSF-APPROVED FOR POTABLE WATER USE, AND SHALL HAVE A MINIMUM COVER OF 36 INCHES. IN SPECIAL CASES WHERE IT IS IMPOSSIBLE OR INAPPROPRIATE TO PROVIDE ADEQUATE COVER, DUCTILE IRON CLASS 350 OR CONCRETE ENCASMENT MAY BE USED AS APPROVED BY THE CITY.
18. ALL PROPOSED WATER MAINS SHALL BE FLUSHED WITH A FULL PIPE DIAMETER, DISINFECTED AND BACTERIOLOGICALLY CLEARED FOR SERVICE IN ACCORDANCE WITH LATEST AWWA STANDARDS AND THE FLORIDA DEPARTMENT OF ENVIRONMENTAL PROTECTION REQUIREMENTS.
19. WATER MAINS SHALL BE AWWA C-900/C-905 CL 150, OR D.I.P. CLASS 350 STANDARD CEMENT LINED.
20. UPON CONSTRUCTION COMPLETION AND ACCEPTANCE OF THE SYSTEM, IT SHALL BE THE DESIGN ENGINEER'S RESPONSIBILITY TO ENSURE THAT THE SYSTEM IS PROPERLY CERTIFIED AND ACCEPTED BY THE REGULATORY AGENCIES, AND THAT CERTIFIED AS-BUILT DRAWINGS ARE PROVIDED TO THE CITY PRIOR TO PAVING AND AFTER BASE, BEFORE ANY USE OF THE SYSTEM. PROVIDE THREE (3) COPIES AS WELL AS A CD OF AUTOCAD DRAWINGS AND PDF FILES OF EACH INDIVIDUAL SHEET. CITY TO APPROVE VERSION OF AUTOCAD.
21. MEGALUG OR EQUIVALENT, RESTRAINED JOINT SYSTEM MAY BE USED ON ALL RESTRAINED FITTINGS, VALVES, ETC. MINIMUM DEPTH OF BURY ON PIPES NOT MEETING REQUIRED COVER REQUIREMENTS SHALL FOLLOW THE MOST RECENT DIPRA THRUST RESTRAINT DESIGN GUIDELINES.



STANDARD CONSTRUCTION DETAIL

GENERAL NOTES  
WATER SYSTEM CONSTRUCTION

INDEX

W-1B

March 2022

**GENERAL NOTES  
WATER SYSTEM CONSTRUCTION**

22. WATER SYSTEMS SHALL BE PRESSURE TESTED AT 150 PSI STATIC PRESSURE FOR A PERIOD OF 2 HOURS PER AWWA STANDARDS. TESTS SHALL BE CONDUCTED BEFORE FINAL PAVING AND AFTER LIME ROCK BASE, AND IN THE PRESENCE OF THE CITY'S INSPECTOR. MAXIMUM PRESSURE LOSS SHALL BE 5 PSI ON THE GAUGE.
23. ALL WATER SERVICES SHALL BE MARKED WITH A "W" SAWCUT INTO THE CURB AND BY METAL TABS SET INTO THE PAVEMENT.
24. ALL WATER VALVES AND BLOW-OFFS SHALL BE MARKED WITH A "V" SAWCUT INTO THE CURB AND BY METAL TABS SET INTO THE PAVEMENT. LOCATION OF METAL TABS IN INCHES FROM EDGE OF PAVEMENT SHALL EQUAL DISTANCE IN FEET FROM EDGE OF PAVEMENT TO VALVE.
25. UNIFLANGE 1300 SERIES PIPE RESTRAINTS AS MANUFACTURED BY FORD OR APPROVED EQUAL MAY BE USED AS APPROPRIATE FOR RESTRAINING IN-LINE PRESSURE PIPE EACH SIDE OF PIPE JOINT. AS REQUIRED BY RESTRAINT TABLE.
26. TRACING WIRE SHALL BE INSTALLED IN ACCORDANCE WITH UTILITY PIPE LOCATION MATERIALS DETAIL.
27. NO GALVANIZED PIPE, FITTINGS, ETC. ARE ACCEPTED.
28. ALL WATER METER BOXES SHALL BE INSTALLED AT THE RIGHT OF WAY LINE ONLY REGARDLESS OF SIZE.
29. SUBMIT ASSEMBLY CERTIFICATION FOR ALL BACKFLOW PREVENTERS TO THE CITY'S UTILITIES DEPARTMENT BEFORE FINAL INSPECTION.
30. PIPING FOR RAW WATER SHALL BE BLUE FOR ABOVE GROUND PIPING, BURIED PVC PIPING SHALL BE BLUE WITH WHITE COLOR BACKGROUND LOCATOR TAPE PLACED DIRECTLY ON TOP OF THE PIPE AND AT 12" TO 18" ABOVE THE PIPE. THE TAPE SHALL CONTINUOUSLY READ "CAUTION - RAW WATER MAIN BURIED BELOW" OR WHITE WITH LOCATOR TAPE PLACED 12" TO 18" ABOVE THE TOP OF THE PIPE.
31. SEE CHART BELOW FOR WATERMAIN SIZE AND MATERIALS.

<b>M A T E R I A L S</b>		
DIAMETER	MATERIAL	STANDARD
2" - 4"	PVC 1120 / SDR 21	ASTM D 2241
> 4" - 12"	PVC 1120 / DR-18	AWWA C 900
> 4" - 12" DEDICATED FIRE LINE	PVC 1120 / DR-18	AWWA C 900
14" - 36" ( 16" - 24" → DR - 18 ) ( 30" - 36" → DR - 18 )	PVC 1120	AWWA C 905
ALL SIZES	HDPE DIPS DR 11	ASTM F 714

NOTE: PVC PIPE COLOR SHALL BE BLUE FOR WATER MAIN, AND LAVENDER FOR REUSE MAIN



**STANDARD CONSTRUCTION DETAIL  
GENERAL NOTES  
WATER SYSTEM CONSTRUCTION**

**INDEX**

**W-1C**

**March 2022**

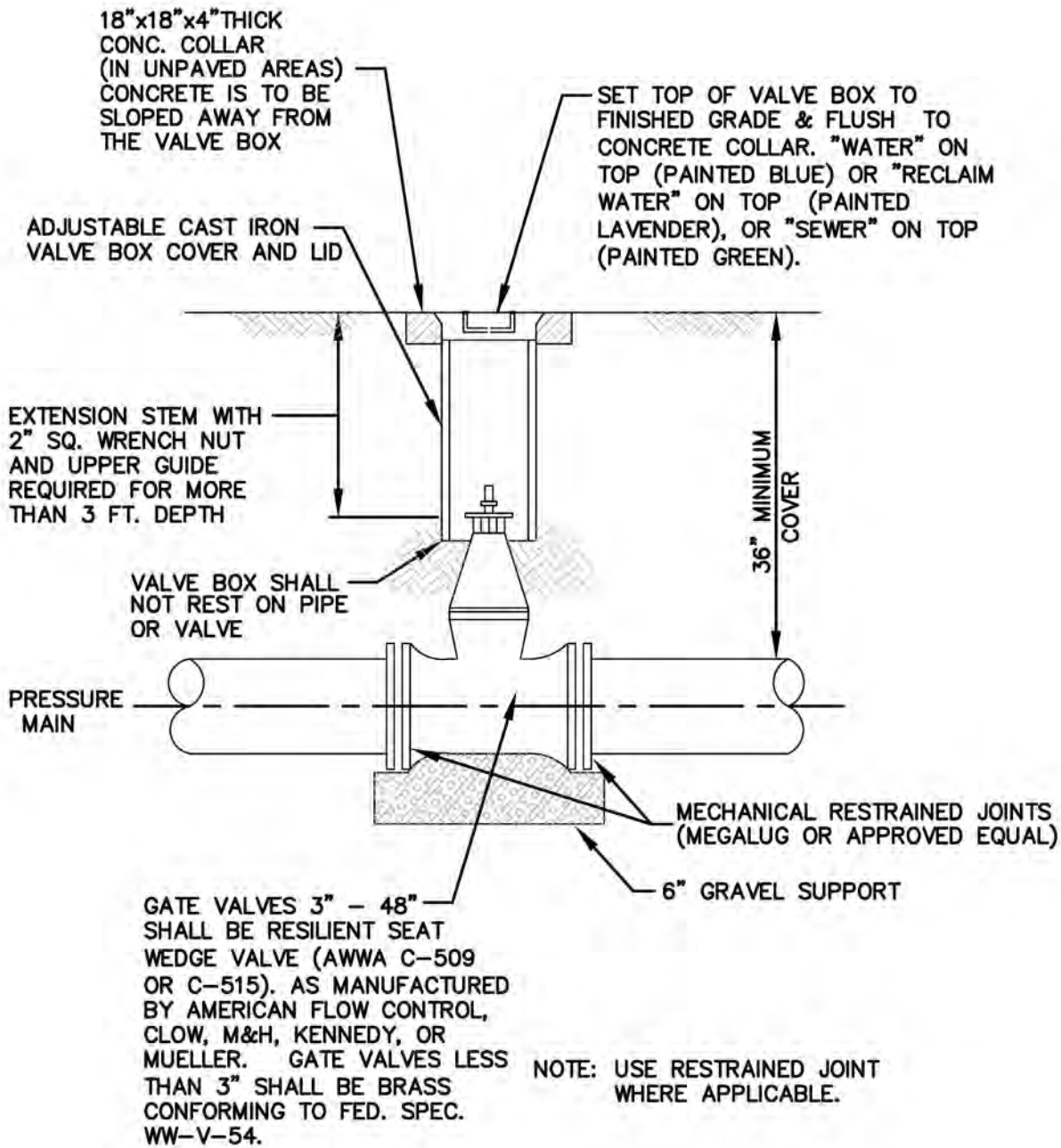

STANDARD CONSTRUCTION DETAIL  
 GATE VALVE AND VALVE BOX  
 NTS.

INDEX

W-2

March 2022

VALVE SCHEDULE FORD OR EQUIVALENT	
WATER SERVICES	
VALVES AT MAIN	
1"	F1000-4
1 1/2"	B81-666 (REQ. C84-66 PACK JOINT COUPLING)
2"	B81-777 (REQ. C84-77 PACK JOINT COUPLING)
VALVES AT METER	
1"	B43-342W-NL
2"	BFA43-777W-NL
REUSE SERVICES	
VALVES AT MAIN AND R/W LINE	
1"	B43-444W-NL
2"	BF43-777W-NL

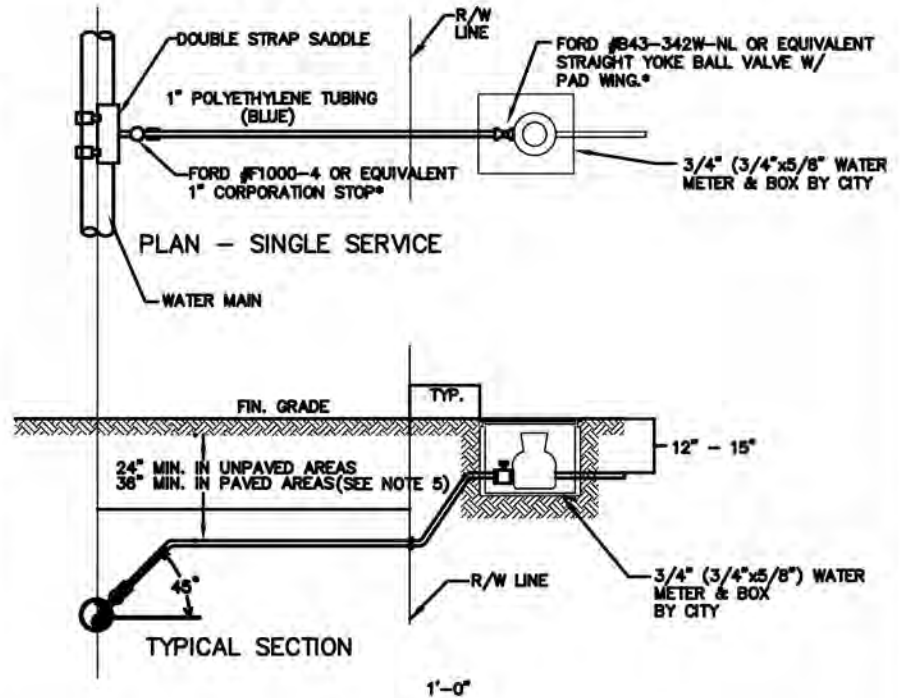

**NOTES:**

1. PE TUBING SHALL BE 200 PSI, NSF APPROVED, SDR 9, MEETING ASTM D1248. TUBING SHALL BE ENDOT ENDOPURE OR APPROVED EQUAL.
2. REDUCED PRESSURE BACKFLOW PREVENTERS ARE REQUIRED FOR ALL COMMERCIAL SERVICES. TO BE INSTALLED BY A CERTIFIED TECHNICIAN AT OWNERS EXPENSE
3. ALL SERVICE TAPS SHALL BE NO CLOSER THAN 2'-0" STAGGERED INTERVAL NOR WITHIN 2'-0" OF BELL OR SPIGOT ENDS.
4. METERS 3" AND LARGER SHALL BE PLACED IN A VAULT TO BE CONSTRUCTED BY DEVELOPER IN ACCORDANCE WITH LDC.
5. IN AREAS TO BE PAVED PROVIDE A 2" MIN. PVC SCHEDULE 40 SLEEVE FOR PE-TUBING. SLEEVE SHALL EXTEND A MIN. OF 2' BEHIND BACK OF CURB AT EACH SIDE OF ROAD.
6. ALL IRRIGATION SERVICES (WATER) MUST HAVE AN APPROVED BACKFLOW PREVENTION DEVICE INSTALLED ON CUSTOMERS SIDE OF WATER METER. THE CUSTOMER IS RESPONSIBLE FOR INSTALLATION AND CERTIFICATION COST. A COPY OF THE CERTIFICATION MUST BE SENT TO THE CITY UTILITIES DEPARTMENT, PRIOR TO FINAL INSPECTION
7. WATER METERS INSTALLED IN AREAS SERVED BY RECLAIMED WATER OR AN ALTERNATE IRRIGATION SUPPLY SHALL BE EQUIPPED WITH DUAL CHECK BACKFLOW PREVENTERS.



STANDARD CONSTRUCTION DETAIL  
WATER LATERAL SERVICE  
NTS

INDEX

W-3

March 2022

SCHEDULE OF LENGTHS OF RESTRAINED PVC PIPE (FT.)					
FITTING	90° BEND	45° BEND	22.5° BEND	11.25° BEND	TEE OR DEAD END
PIPE SIZE (IN.) :					
4"	21	18	18	18	47
6"	30	18	18	18	66
8"	38	18	18	18	86
10"	45	28	18	18	103
12"	53	22	18	18	121
14"	61	26	18	18	140
16"	66	28	18	18	154
18"	73	30	18	18	170
20"	79	33	18	18	186
24"	87	36	18	18	208
30"	102	42	20	18	248

TABLE APPLIES TO PVC PIPE FOR THE FOLLOWING CONDITIONS:  
 TEST PRESSURE: 150 PSIG  
 SOIL TYPE: SP  
 COVER DEPTH: 2.5 FEET  
 SAFETY FACTOR: 1.5  
 TRENCH TYPE: 3

LENGTHS BETWEEN HEAVY LINES INDICATE ONE FULL LENGTH (18' MIN.) OF PIPE TO BE RESTRAINED.

TABLE SHOWS MINIMUM LENGTH OF PIPE EACH WAY FROM FITTING FOR WHICH RESTRAINT IS REQUIRED.

SCHEDULE OF LENGTHS OF RESTRAINED DIP (FT.)					
FITTING	90° BEND	45° BEND	22.5° BEND	11.25° BEND	TEE OR DEAD END
PIPE SIZE (IN.) :					
4"	21	18	18	18	37
6"	30	18	18	18	52
8"	38	18	18	18	67
10"	45	18	18	18	81
12"	52	22	18	18	94
14"	60	25	18	18	107
16"	66	27	18	18	120
18"	74	31	18	18	132
20"	80	33	18	18	144
24"	92	38	18	18	167
30"	106	44	21	18	199
36"	86	36	18	18	170
42"	95	40	18	18	191
48"	117	43	18	18	212

TABLE APPLIES TO D.I.P. FOR THE FOLLOWING CONDITIONS:  
 TEST PRESSURE: 150 PSIG  
 SOIL TYPE: SP  
 COVER DEPTH: 2.5 FEET  
 SAFETY FACTOR: 1.5  
 TRENCH TYPE: 2

LENGTHS BETWEEN HEAVY LINES INDICATE ONE FULL LENGTH (18' MIN.) OF PIPE TO BE RESTRAINED.

TABLE SHOWS MINIMUM LENGTH OF PIPE EACH WAY FROM FITTING FOR WHICH RESTRAINT IS REQUIRED.



STANDARD CONSTRUCTION DETAIL  
 PVC AND D.I.P. RESTRAINED JOINT TABLE

INDEX

W-5

March 2022

ACCEPTABLE MANUFACTURERS:  
ZURN WILKINS MODEL 950XL, WATTS MODEL 009 OR APPROVED EQUAL

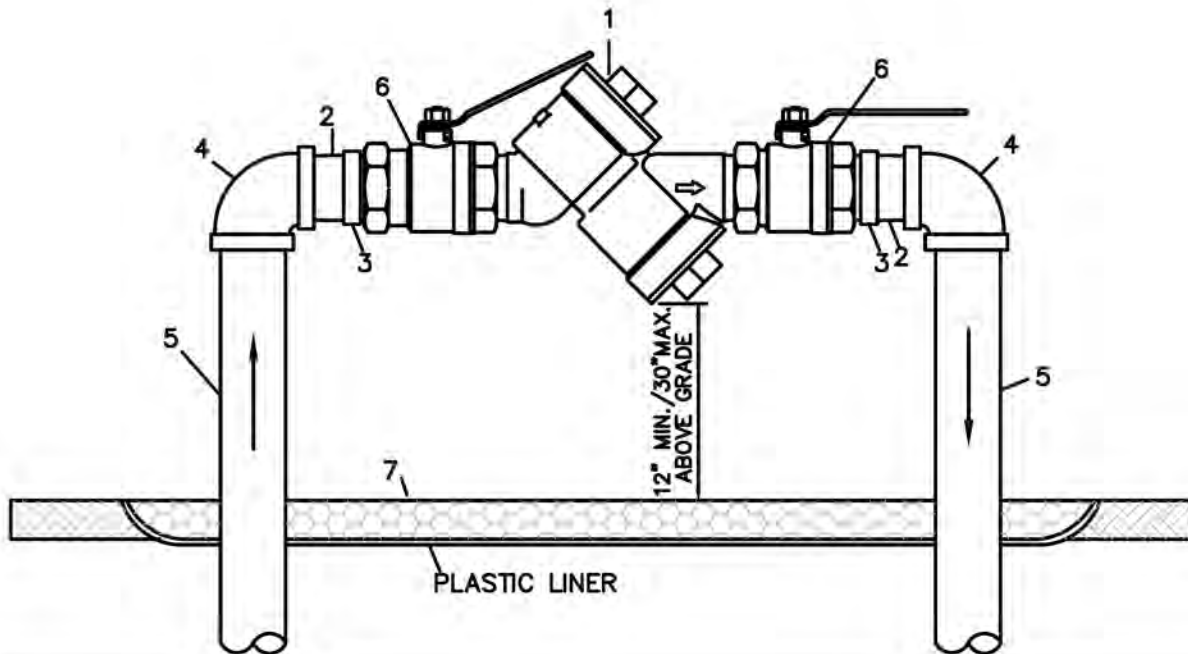

M A T E R I A L S		
ITEM	QUANT.	DESCRIPTION
1	1	3/4", 1", 1-1/2" OR 2" BACKFLOW PREVENTER ASSEMBLY
2	2	3/4", 1", 1-1/2" OR 2" x NOM. NIPPLES - BRASS
3	2	3/4", 1", 1-1/2" OR 2" THREADED UNION - BRASS
4	2	3/4", 1", 1-1/2" OR 2" x 90° ELBOWS - BRASS
5	2	3/4", 1", 1-1/2" OR 2" x VARIES RISER - BRASS
6	2	3/4", 1", 1-1/2" OR 2" BALL VALVE - BRASS
7	*	3000 PSI CONCRETE (MIN 4" THICK)

- NOTE:
- FIELD ADJUST AND CUT ITEM 4 TO THE PROPER LENGTH.
  - NO GALVANIZED PIPE OR FITTINGS ALLOWED.
  - A COPY OF THE ASSEMBLY CERTIFICATION SHALL BE SUBMITTED TO THE CITY'S UTILITIES DEPARTMENT BEFORE FINAL INSPECTION
  - ASSEMBLY SHOULD HAVE ADEQUATE LANDSCAPING AROUND IT TO OBSCURE VIEW.
  - ASSEMBLY SHALL BE PAINTED DARK BLUE



STANDARD CONSTRUCTION DETAIL  
DOUBLE CHECK BACKFLOW PREVENTER  
(FIRE LINE)  
3/4", 1", 1-1/2", OR 2"  
NTS.

INDEX

W-6A

March 2022

ACCEPTABLE MANUFACTURERS:  
 ZURN WILKINS MODEL 375, WATTS MODEL 009 WITH OS&Y VALVES, OR APPROVED EQUAL

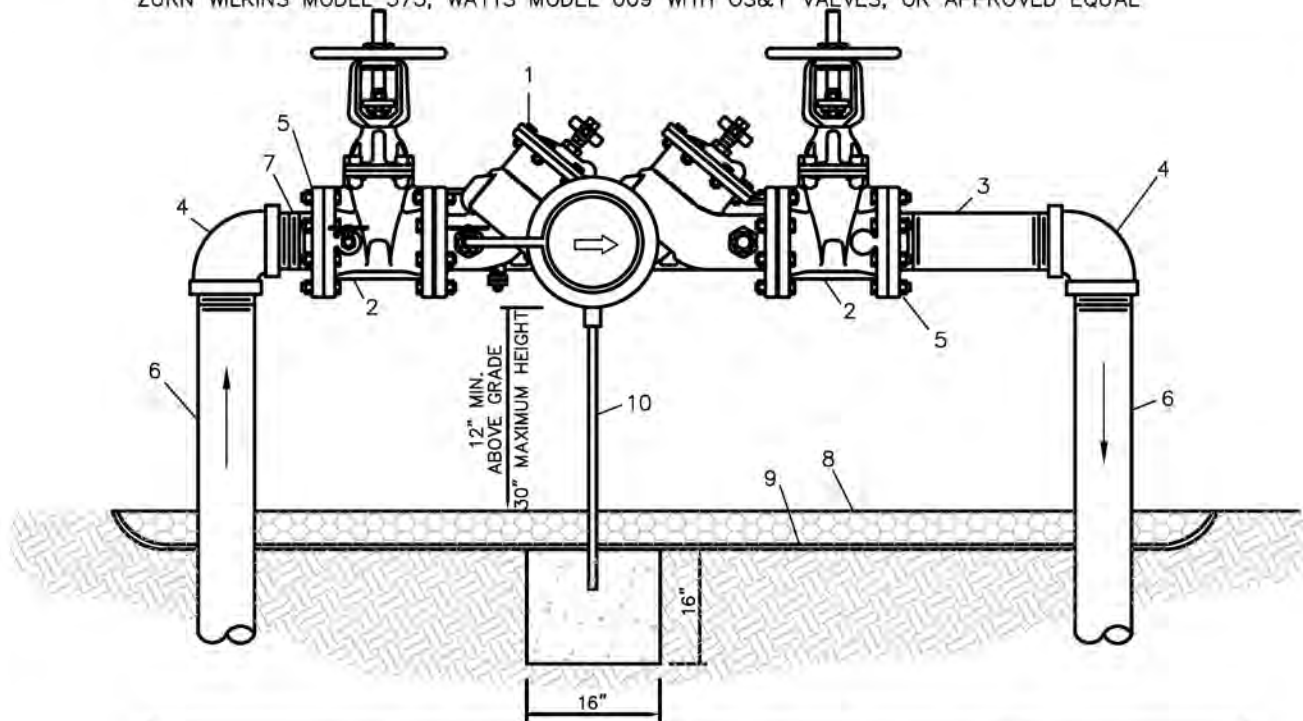

M A T E R I A L S		
ITEM	QUANT.	DESCRIPTION
1	1	3", 4" VALVE, REDUCED PRESSURE BACKFLOW PREVENTER
2	2	3", 4" VALVE, GATE, C.I., F-F
3	1	3", 4" NIPPLE, D.I., OR BRASS (12" LONG) (OPT.)
4	2	3", 4" ELBOW, D.I., OR BRASS - 90°
5	2	3", 4" FLANGE
6	2	3", 4" PIPE, D.I., OR BRASS (42" LONG)
7	1	3", 4" NIPPLE, D.I., OR BRASS (6" LONG)
8	*	3000 P.S.I. CONCRETE SLAB (MIN. 4" THICK)
9	*	PLASTIC LINER
10	1	PIPE SUPPORT / CONCRETE FOUNDATION

NOTE: -FIELD ADJUST AND CUT ITEM 3 TO THE PROPER LENGTH.  
 -ASSEMBLY SHALL BE PAINTED DARK BLUE.  
 -A COPY OF THE ASSEMBLY CERTIFICATION SHALL BE SUBMITTED TO THE CITY'S UTILITIES DEPARTMENT BEFORE FINAL INSPECTION  
 -ASSEMBLY SHOULD HAVE ADEQUATE LANDSCAPING AROUND IT TO OBSCURE VIEW.  
 C-900 OR D.I. PIPE AND FITTINGS SHALL BE RESTRAINED. COPPER PIPE AND FITTINGS SHALL BE SWEATED. BRASS PIPE AND FITTINGS SHALL BE THREADED. NO GALVANIZED PIPE OR FITTINGS ALLOWED.



STANDARD CONSTRUCTION DETAIL  
 REDUCED PRESSURE BACKFLOW PREVENTER  
 (POTABLE WATER) 3" OR 4"

NTS

INDEX

W-6B

March 2022



ACCEPTABLE MANUFACTURERS:  
 WILKINS MODEL 975, WATTS MODEL 909 WITH  
 OS&Y VALVES OR APPROVED EQUAL

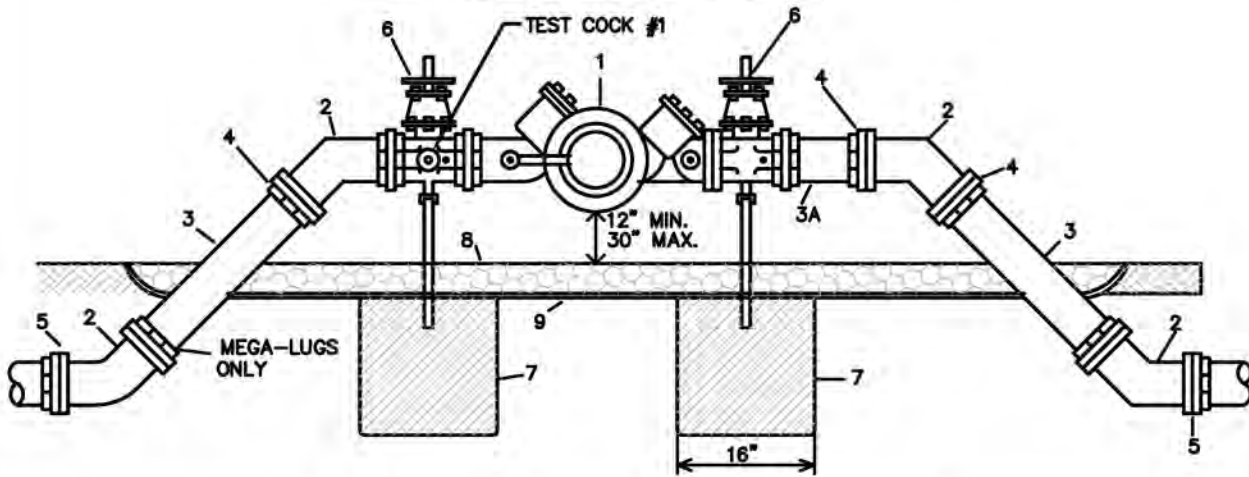

M A T E R I A L S		
ITEM	QUANT.	DESCRIPTION
1	1	6", 8" VALVE, REDUCED PRESSURE BACKFLOW PREVENTER.
2	4	6", 8" BEND -45°
3	2	6", 8" ADAPTER, D.I.P. F - PE
3A	1	6", 8" ADAPTER, D.I.P. F - PE (OPT.)
4	3	6", 8" ADAPTER FLANGE D.I.P.
5	2	6", 8" ADAPTER FLANGE P.V.C. (DR - 18)
6	2	6", 8" VALVE, GATE, C.I., F-F (OS&Y STYLE ONLY)
7	1 or 2	2" IRON PIPE/CONCRETE FOUNDATION
8	*	3000 P.S.I. CONCRETE SLAB (MIN. 4" THICK)
9	*	PLASTIC LINER

- NOTE:
- FIELD ADJUST AND CUT ITEM 3 TO THE PROPER LENGTH.
  - DO NOT INTERCHANGE ITEMS 4 AND 5.
  - ASSEMBLY SHALL BE PAINTED DARK BLUE
  - NO GALVANIZED PIPE OR FITTINGS ALLOWED.
  - A COPY OF THE ASSEMBLY CERTIFICATION SHALL BE SUBMITTED TO THE CITY'S UTILITIES DEPARTMENT BEFORE FINAL INSPECTION
  - ASSEMBLY SHOULD HAVE ADEQUATE LANDSCAPING AROUND IT TO OBSCURE VIEW.



STANDARD CONSTRUCTION DETAIL  
 REDUCED PRESSURE BACKFLOW PREVENTER  
 (POTABLE WATER) 6" OR 8"

NTS

INDEX

W-6C

March 2022

ACCEPTABLE MANUFACTURERS:  
 ZURN WILKINS MODEL 975XL, WATTS MODEL 009 QTS, OR APPROVED EQUAL

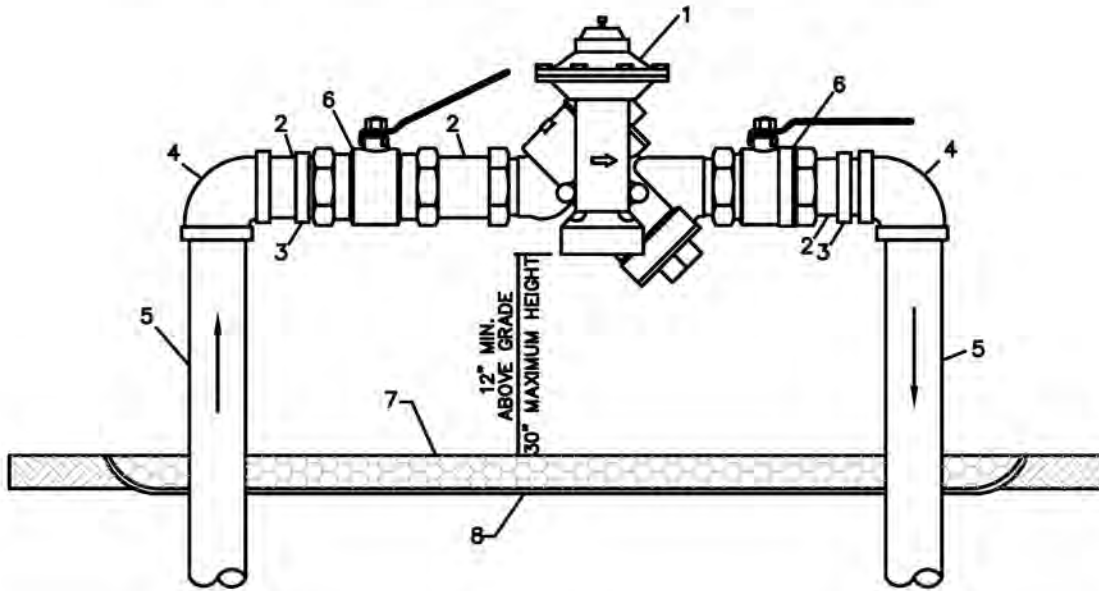

M A T E R I A L S		
ITEM	QUANT.	DESCRIPTION
1	1	3/4", 1", 1-1/2" OR 2" BACKFLOW PREVENTER ASSEMBLY
2	3	3/4", 1", 1-1/2" OR 2" x NOM. NIPPLES - BRASS
3	2	3/4", 1", 1-1/2" OR 2" THREADED UNION - BRASS
4	2	3/4", 1", 1-1/2" OR 2" x 90° ELBOWS - BRASS
5	2	3/4", 1", 1-1/2" OR 2" x VARIES RISER - BRASS
6	2	3/4", 1", 1-1/2" OR 2" BALL VALVE
7	*	3000 P.S.I. CONCRETE SLAB (MIN. 4" THICK)
8	*	PLASTIC LINER

- NOTE:
- FIELD ADJUST AND CUT ITEM 4 TO THE PROPER LENGTH.
  - NO GALVANIZED FITTINGS OR PIPE ALLOWED.
  - A COPY OF THE ASSEMBLY CERTIFICATION SHALL BE SUBMITTED TO THE CITY'S UTILITIES DEPARTMENT BEFORE FINAL INSPECTION.
  - ASSEMBLY SHOULD HAVE ADEQUATE LANDSCAPING AROUND IT TO OBSCURE VIEW.
  - ASSEMBLY SHALL BE PAINTED DARK BLUE



STANDARD CONSTRUCTION DETAIL  
 REDUCED PRESSURE BACKFLOW PREVENTER  
 (POTABLE WATER & IRRIGATION)  
 3/4", 1", 1 1/2", OR 2"

NTS

INDEX

W-6D

March 2022

ACCEPTABLE MANUFACTURERS:  
 ZURN WILKINS MODEL 350ADA, WATTS MODEL 009 OS&Y, OR APPROVED EQUAL

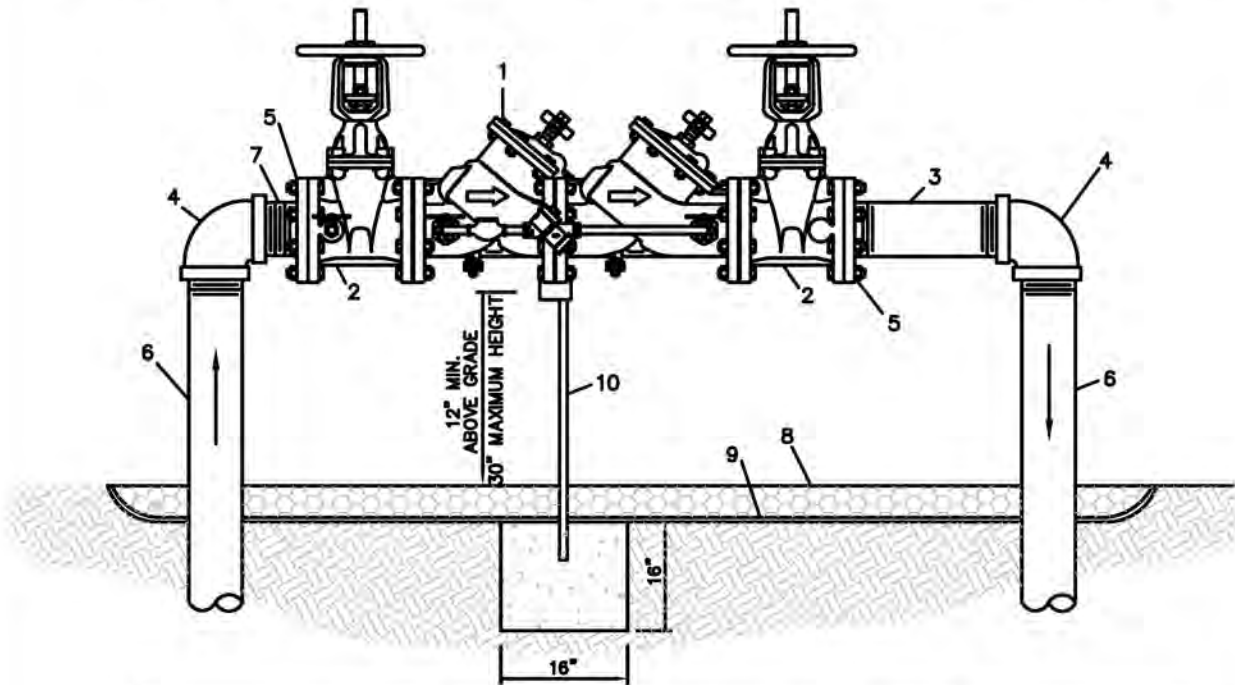

M A T E R I A L S		
ITEM	QUANT.	DESCRIPTION
1	1	4", 6", 8", 10" VALVE, DOUBLE CHECK BACKFLOW PREVENTER
2	2	4", 6", 8", 10" VALVE, GATE, C.I., F-F
3	1	4", 6", 8", 10" NIPPLE, BRASS, OR D.I., (12" LONG) (OPT.)
4	2	4", 6", 8", 10" ELBOW, BRASS, OR D.I., - 90°
5	2	4", 6", 8", 10" FLANGE, STEEL PIPE, SCREW-TYPE
6	2	4", 6", 8", 10" PIPE, BRASS, OR D.I. (42" LONG)
7	1	4", 6", 8", 10" NIPPLE, BRASS, OR D.I. (6" LONG)
8	*	3000 P.S.I. CONCRETE SLAB (MIN. 4" THICK)
9	*	PLASTIC LINER
10	1	PIPE SUPPORT / CONCRETE FOUNDATION

- NOTE:
- FIELD ADJUST AND CUT ITEM 6 TO THE PROPER LENGTH.
  - NO GALVANIZED FITTINGS OR PIPE ALLOWED.
  - A COPY OF THE ASSEMBLY CERTIFICATION SHALL BE SUBMITTED TO THE CITY'S UTILITIES DEPARTMENT BEFORE FINAL INSPECTION.
  - ASSEMBLY SHOULD HAVE ADEQUATE LANDSCAPING AROUND IT TO OBSCURE VIEW.
  - ASSEMBLY SHALL BE PAINTED DARK BLUE.



STANDARD CONSTRUCTION DETAIL  
 DOUBLE CHECK DETECTOR BACKFLOW PREVENTER  
 (DEDICATED FIRE LINE) 4", 6", 8", 10"  
 NTS

INDEX

W-6E

March 2022

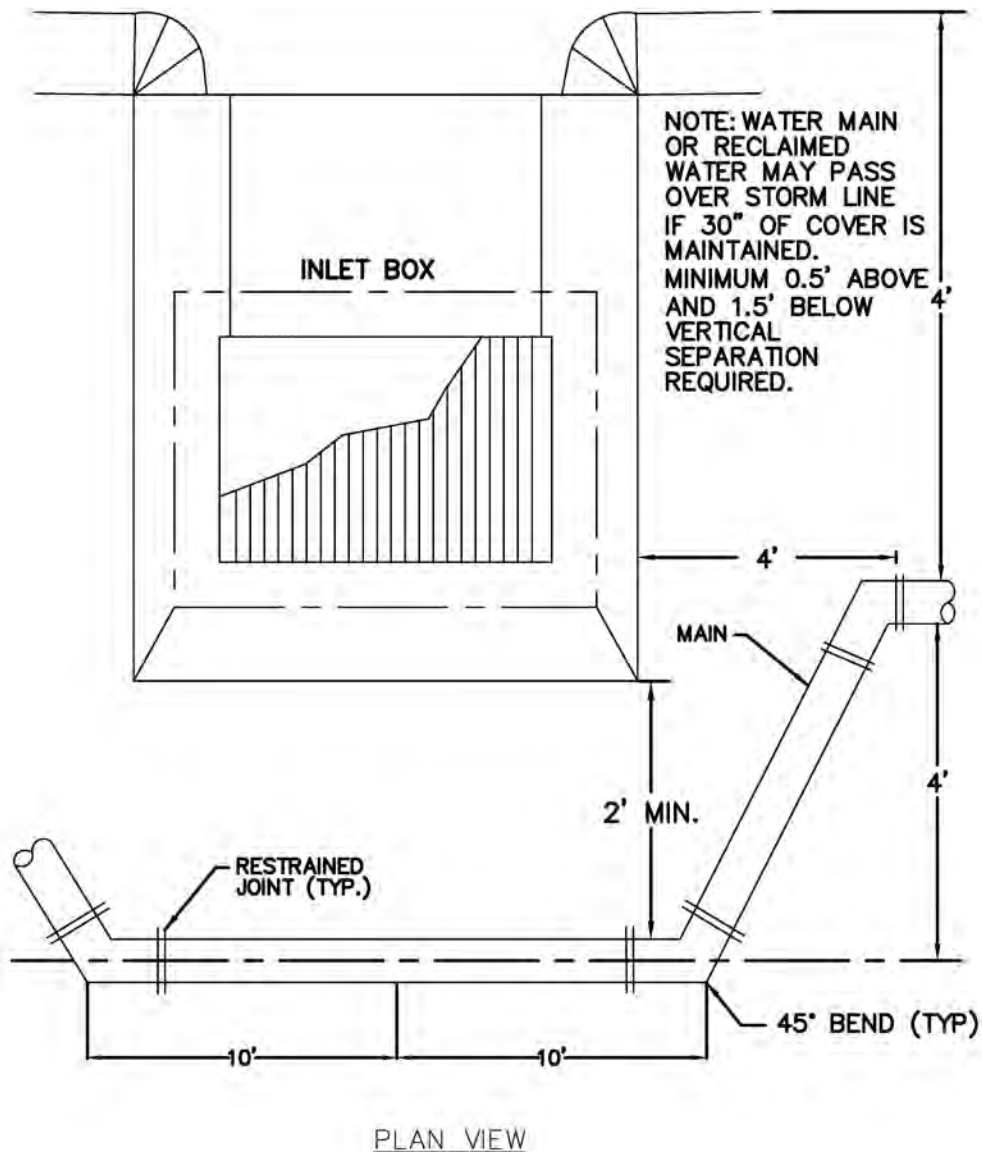

STANDARD CONSTRUCTION DETAIL  
 WATER MAIN INSTALLATION BETWEEN  
 DRAINAGE INLET AND SIDEWALK  
 NTS

INDEX

W-7

March 2022

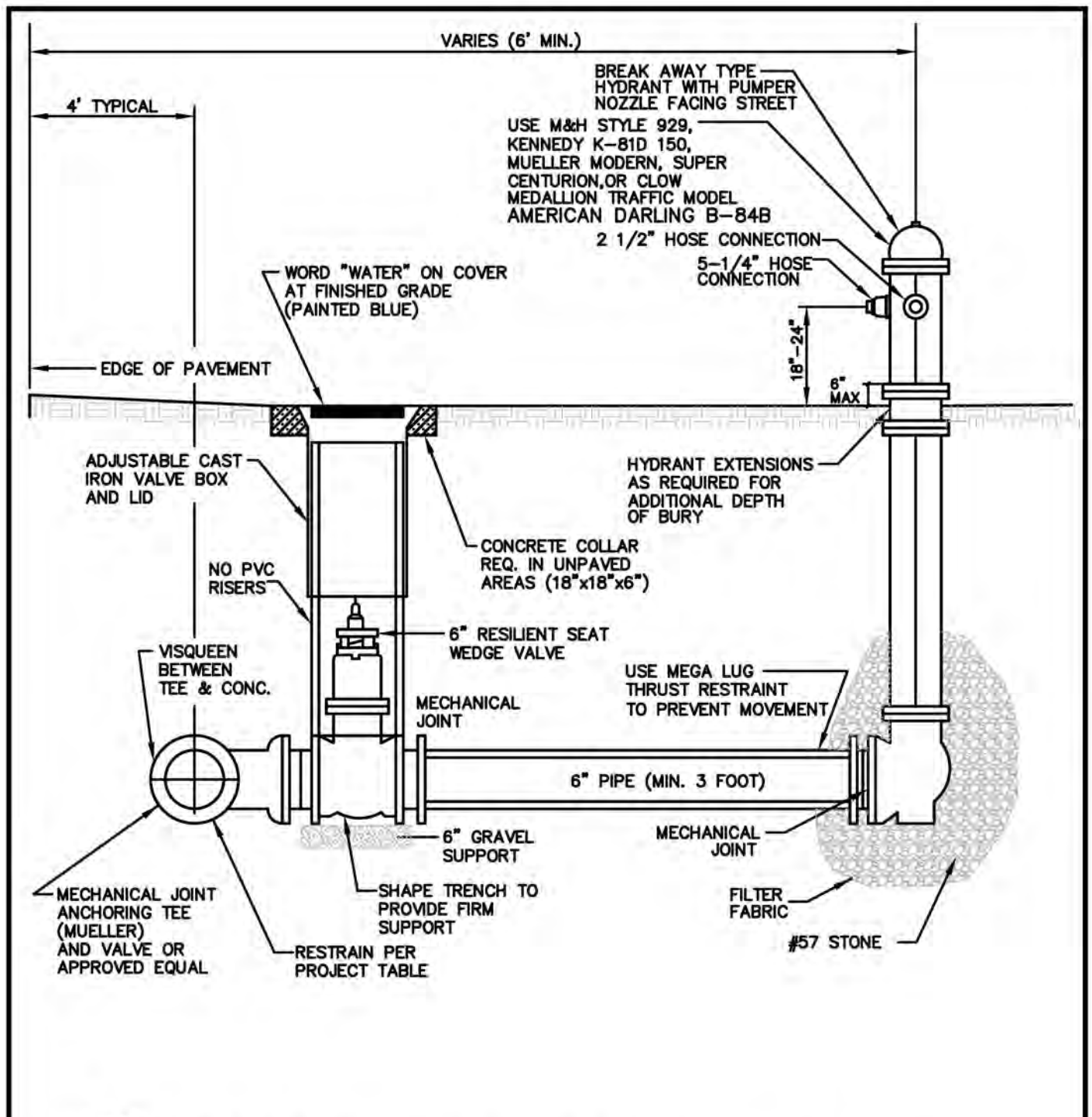

**NOTES:**

1. ALL JOINTS SHALL BE RESTRAINED
2. HYDRANTS TO BE PAINTED SAFETY YELLOW (PUBLIC) OR RED BONNET (PRIVATE) COLOR.
3. HOSE CONNECTIONS TO BE AMERICAN STANDARD THREADS
4. THE HYDRANT SHOE WILL BE COATED INSIDE WITH FUSION BONDED EPOXY. 6 MIL MINIMUM
5. ADJUSTMENTS OR REPAIRS TO THE HYDRANT AFTER INSTALLATION SHALL BE DONE BY AN UNDERGROUND UTILITY CONTRACTOR OR THE CITY AND ALL COST SHALL BE CHARGED TO THE DEVELOPER. PAYMENT SHALL BE MADE PRIOR TO CERTIFICATE OF OCCUPANCY OF PROPERTY.



**STANDARD CONSTRUCTION DETAIL**  
**FIRE HYDRANT ASSEMBLY**  
 NTS

INDEX

W-8

March 2022

STANDARD CONSTRUCTION DETAIL  
WATER MAIN SEPARATION  
NTS

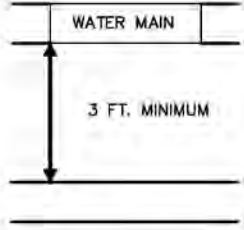
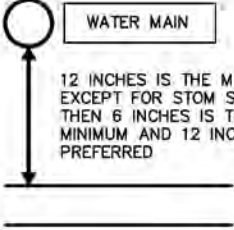
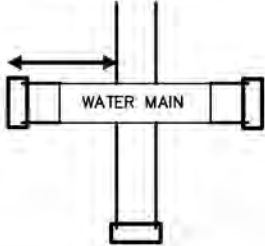
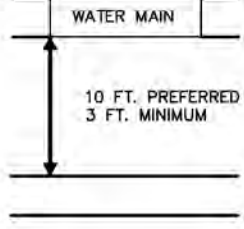
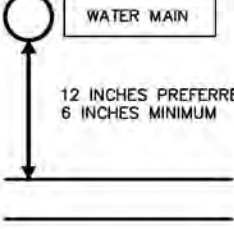
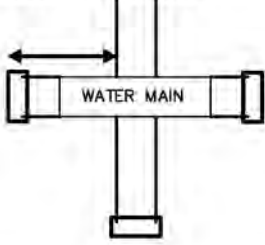
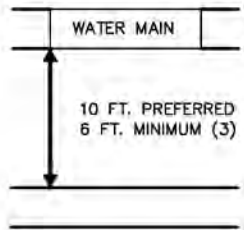
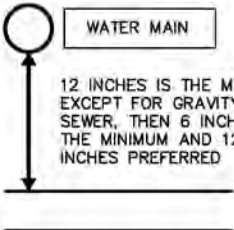
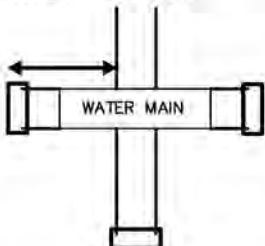

OTHER PIPE	HORIZONTAL SEPARATION	CROSSINGS (1)	JOINT SPACING & CROSSINGS (FULL JOINT CENTERED)
STORM SEWER, STORM WATER FORCEMAIN, RECLAIMED WATER (2)	 <p>3 FT. MINIMUM</p>	 <p>12 INCHES IS THE MINIMUM, EXCEPT FOR STOM SEWER, THEN 6 INCHES IS THE MINIMUM AND 12 INCHES PREFERRED</p>	<p>ALTERNATE 3 FT. MINIMUM</p> 
VACUUM SANITARY SEWER	 <p>10 FT. PREFERRED 3 FT. MINIMUM</p>	 <p>12 INCHES PREFERRED 6 INCHES MINIMUM</p>	<p>ALTERNATE 3 FT. MINIMUM</p> 
GRAVITY OR PREASURE SANITARY SEWER, SANITARY FORCEMAIN, RECLAIMED WATER (4)	 <p>10 FT. PREFERRED 6 FT. MINIMUM (3)</p>	 <p>12 INCHES IS THE MINIMUM, EXCEPT FOR GRAVITY SEWER, THEN 6 INCHES IS THE MINIMUM AND 12 INCHES PREFERRED</p>	<p>ALTERNATE 6 FT. MINIMUM</p> 
ON-SITE SEWAGE TREATMENT & DISPOSAL SYSTEM	10 FT. MINIMUM	—	—

(1) WATER MAIN SHOULD CROSS ABOVE OTHER PIPE. WHEN WATER MAIN MUST BE BELOW OTHER PIPE, THE MINIMUM SEPARATION IS 18 INCHES.  
 (2) RECLAIMED WATER REGULATED UNDER PART III OF CHAPTER 62-610, F.A.C.  
 (3) 3 FT. FOR GRAVITY SEWER WHERE BOTTOM OF THE WATER MAIN IS LAID AT LEAST 6 INCHES ABOVE THE TOP OF THE GRAVITY SANITARY SEWER.  
 (4) RECLAIMED WATER NOT REGULATED UNDER PART III OF CHAPTER 62-610, F.A.C.

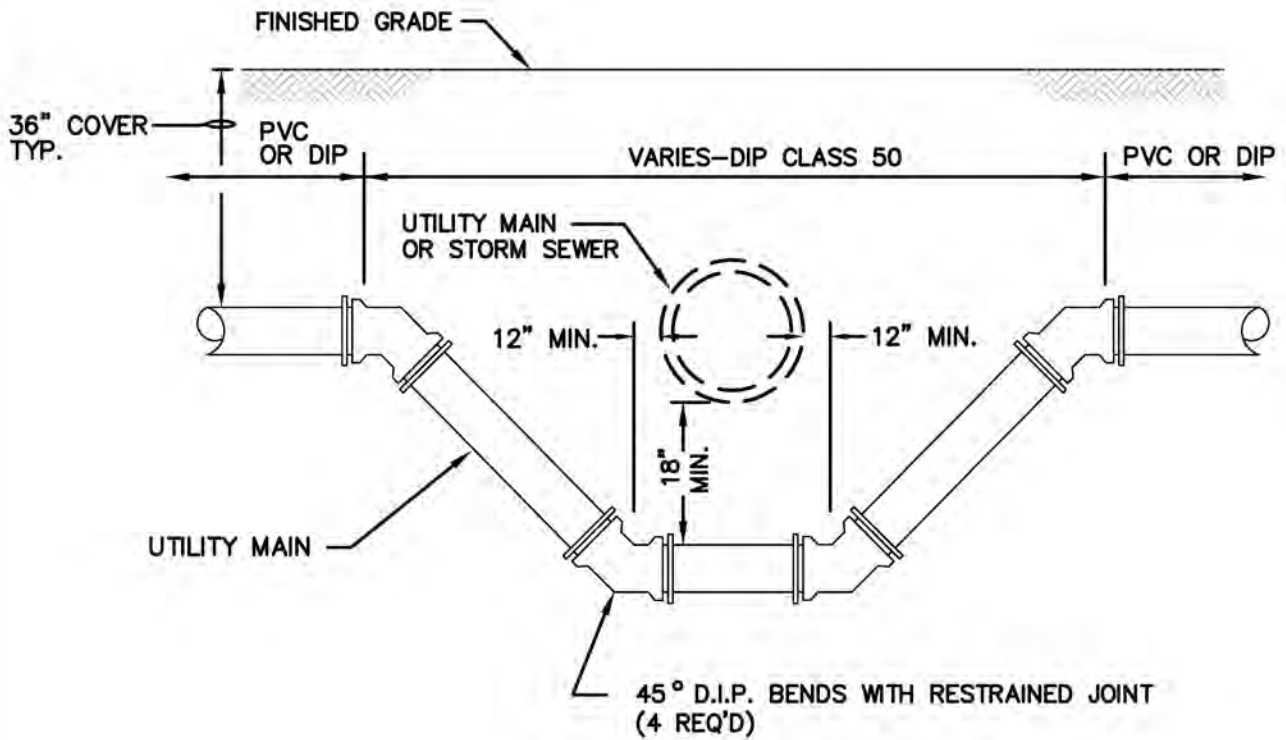

NOTE: ABOVE DETAIL TO BE UTILIZED IF CONTRACTOR CANNOT MAINTAIN 18" CLEAR BETWEEN MAINS BY DEFLECTING PIPE IN ACCORDANCE WITH MANUFACTURER'S RECOMMENDATIONS.



STANDARD CONSTRUCTION DETAIL  
 PIPE CROSSING  
 NTS.

INDEX

W-9B

March 2022

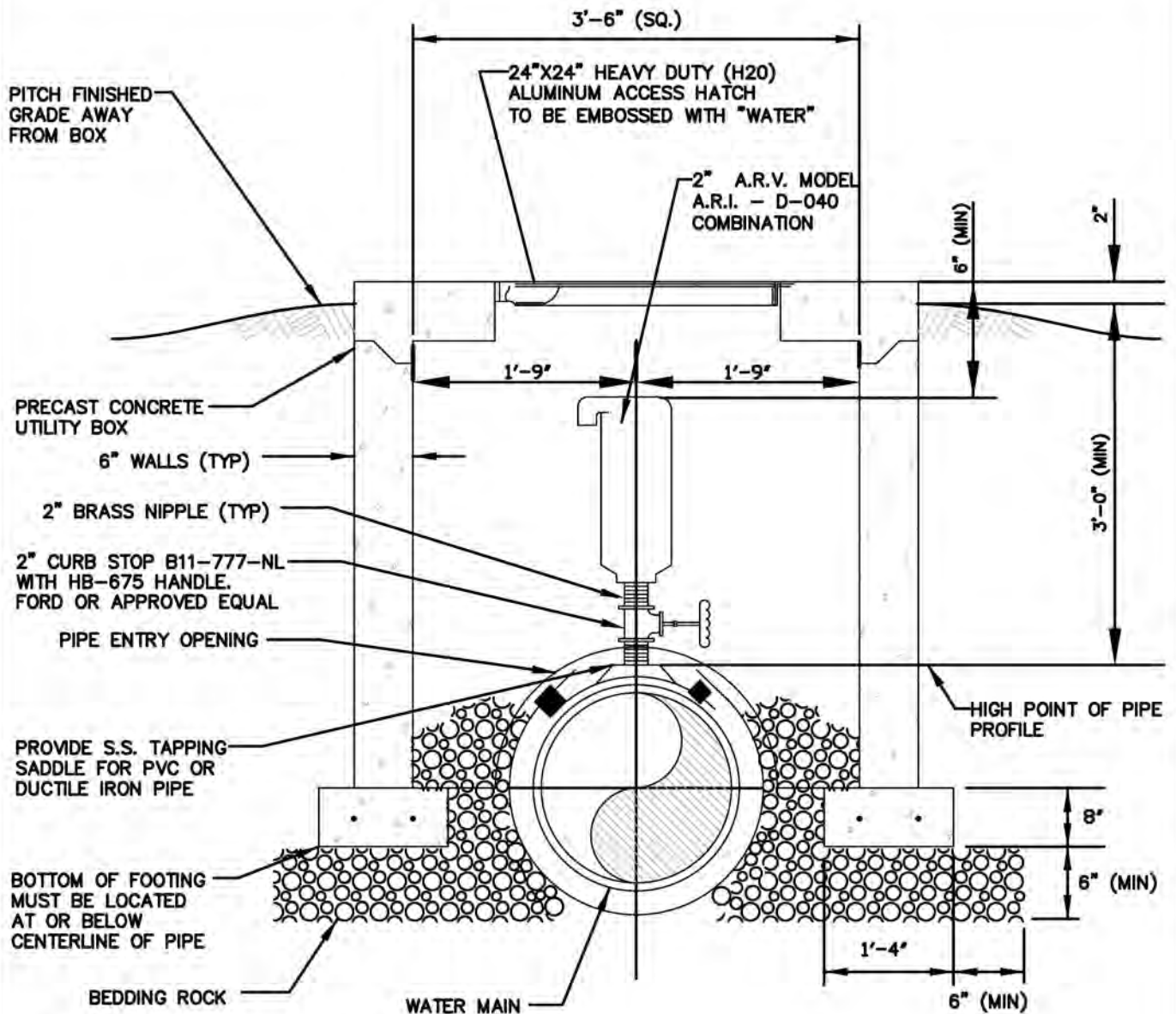

**NOTE:**

1. GALVANIZED PIPE AND FITTINGS NOT ACCEPTABLE FOR THIS INSTALLATION
2. STRUCTURE TO BE ADEQUATE FOR AASHTO H20 LOADING
3. DESIGNER IS RESPONSIBLE FOR PROVIDING CONSTRUCTION MATERIAL AND STEEL REINFORCING REQUIREMENTS
4. NO SURFACE COATING REQUIRED ON VAULT
5. ALUMINUM HATCH TO INCLUDE S.S. HINGE AND S.S. SLAM LOCKS WITH REMOVABLE KEYS
6. FITTINGS AND PIPE FOR A.R.V. SHALL BE BRASS



**STANDARD CONSTRUCTION DETAIL  
AUTOMATIC AIR RELEASE VALVE  
(WATER MAIN)**

NTS

INDEX

W-10

March 2022



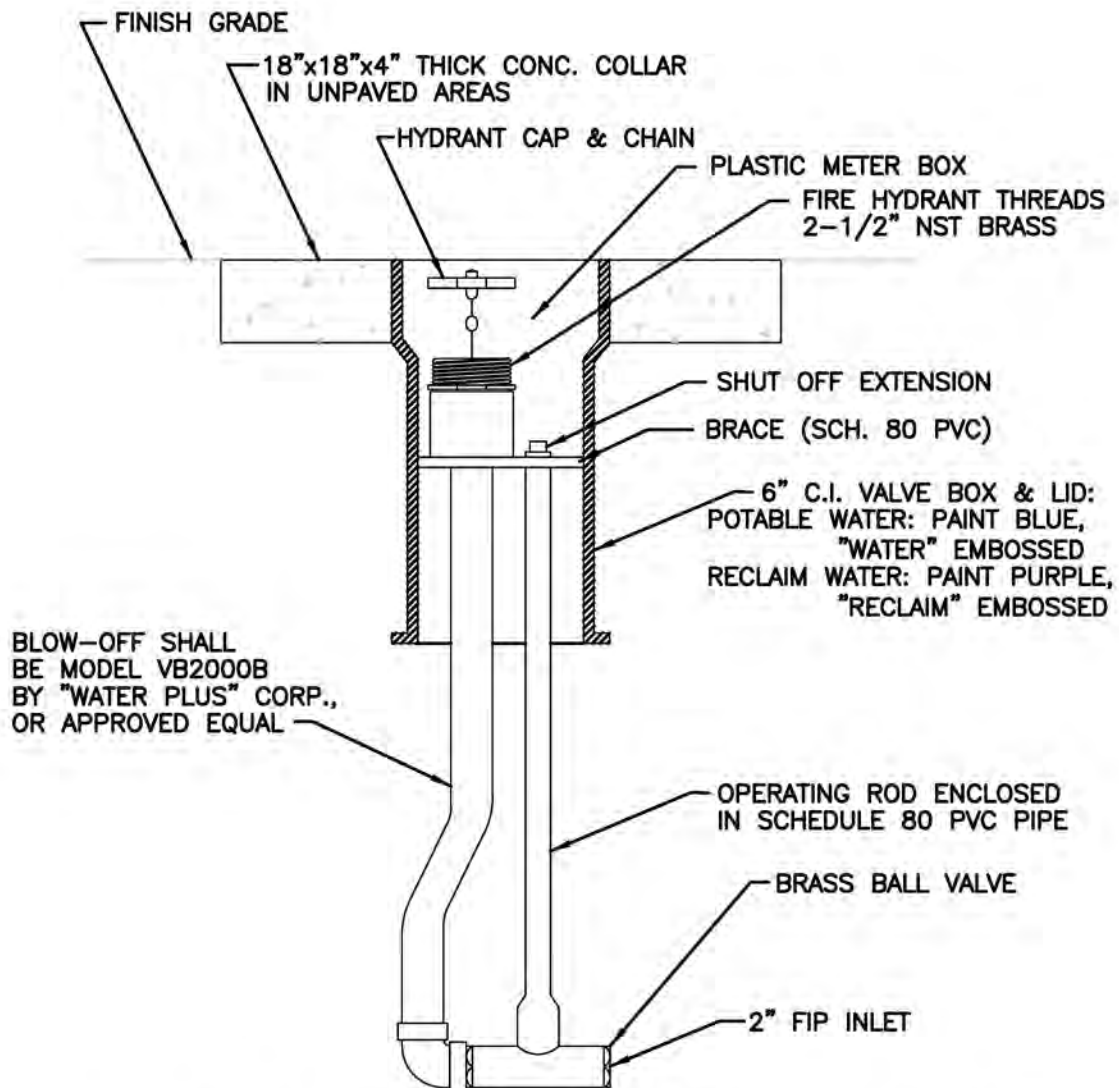

1. WRENCH AND DISCHARGE SPOUT AS SUPPLIED BY MANUFACTURER SHALL BE TURNED OVER TO THE CITY DURING FINAL INSPECTION.



STANDARD CONSTRUCTION DETAIL  
BLOW-OFF ASSEMBLY  
NTS.

INDEX

W-11

March 2022

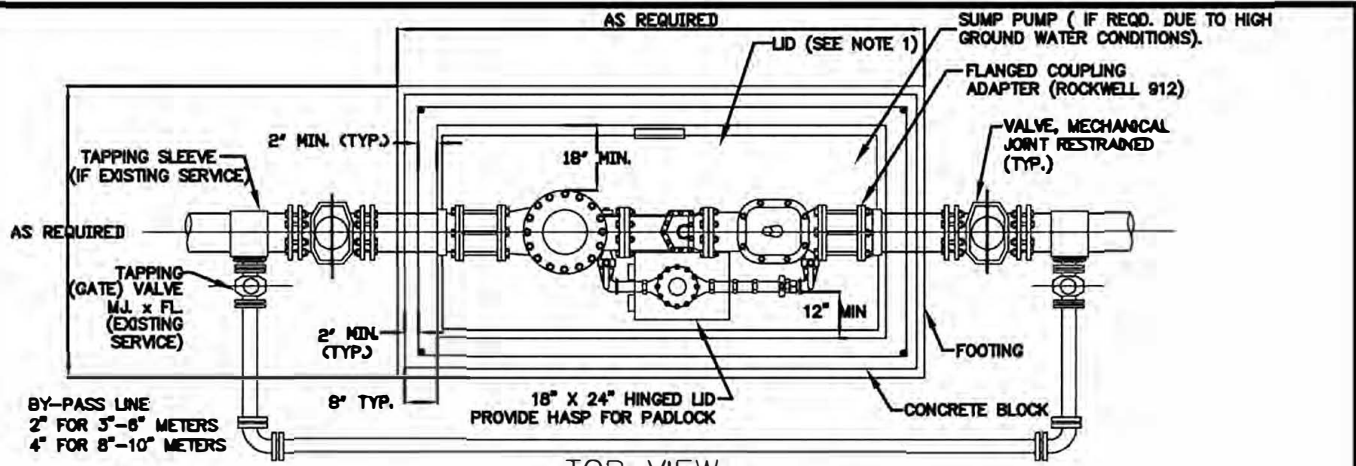

TOP VIEW

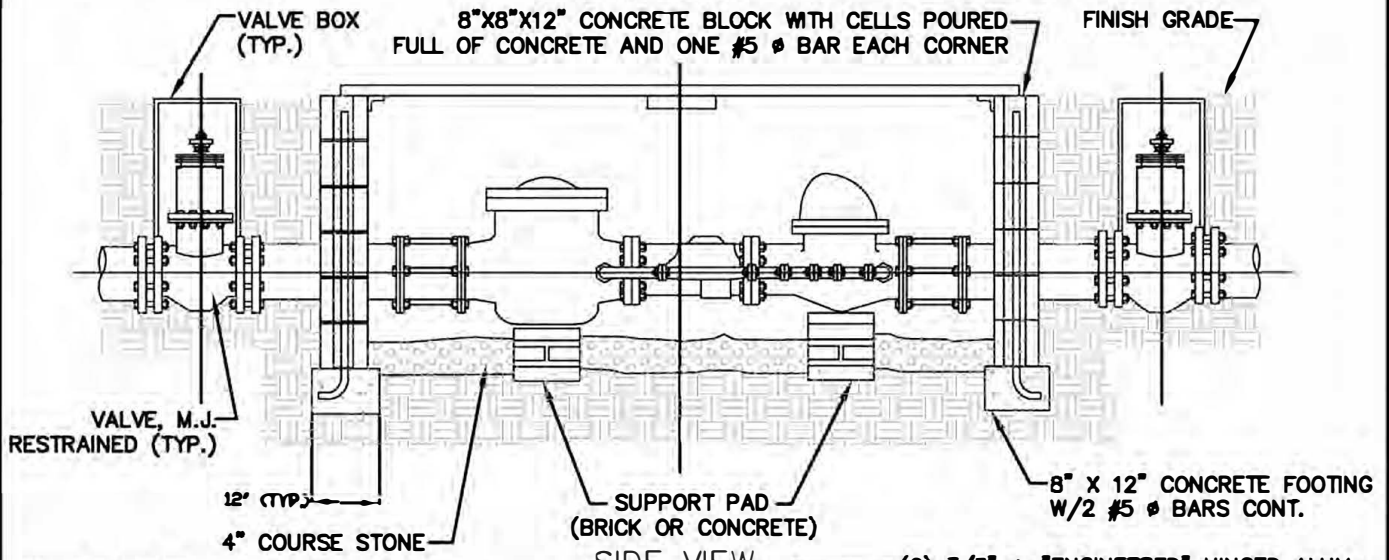

SIDE VIEW

**WATER METER ASSEMBLY NOTES**

1. LID SHALL BE ALUMINUM DIAMOND PATTERN PLATE AS MANUFACTURED BY HALLIDAY PRODUCTS.
2. AS AN ALTERNATIVE TO CONSTRUCTING THE VAULT ON SITE, A PRECAST VAULT AS MANUFACTURED BY BROOKS PRODUCTS OR AN APPROVED EQUAL IS AN OPTION.
3. UNLESS OTHERWISE SPECIFIED BY THE ENGINEER, GATE VALVES SHALL BE INSTALLED ON MAINS LESS THAN 12" AND BUTTERFLY VALVES FOR MAINS 12" AND GREATER.
4. THE WATER SERVICE METER SHALL BE A NEPTUNE WATER METER WITH A 2" SEALED REGISTER METER. METERS SHALL REGISTER IN GALLONS, BE STRAIGHT READING AND CONFORM TO AWWA C-700 LATEST. METER TYPE SHALL BE APPROVED BY THE UTILITIES MANAGER.
5. WATER SERVICE METERS SERVICING A FIRE PROTECTION SYSTEM SHALL BE NEPTUNE HIGH PERFORMANCE PROTECTUS III FIRE SERVICE METER.
6. METERS 3" AND LARGER TO HAVE A 2" TEST PORT.
7. WATER METER REGISTER SHALL BE THE TOUCH READ ECR TYPE.
8. TOUCH READ DEVICE SHALL BE MOUNTED IN VAULT LID AS RECOMMENDED BY THE MANUFACTURER.
9. USE DIP.
10. METER UP TO 2" TO BE SUPPLIED AND SET BY THE CITY. SERVICE AND PROPERTY INSTALLATION TO BE BY CONTRACTOR.
11. ANY METERS OVER 2" TO BE SUPPLIED, SET AND INSTALLED BY CONTRACTOR.

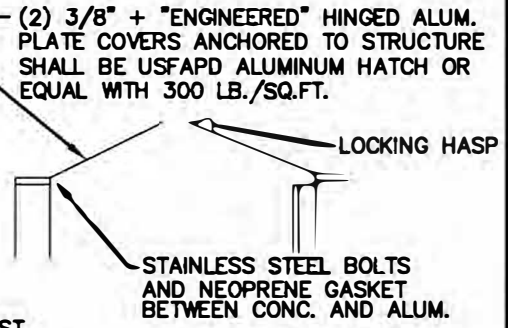

INSIDE VAULT DIMENSIONS SHALL BE AS FOLLOWS:

3" METERS	4' X 5'
4" METERS	4' X 6'
6" METERS	5' X 8'
8" METERS	6' X 8'
10" METERS	7' X 8'



**STANDARD CONSTRUCTION DETAIL**  
**WATER METER ASSEMBLY**

NTS

INDEX

W-12

March 2022

## SANITARY SEWER CONSTRUCTION GENERAL NOTES

1. THE CITY'S PUBLIC UTILITY DEPARTMENT SHALL BE NOTIFIED PRIOR TO BEGINNING ANY SEWER CONSTRUCTION.
2. ALL GRAVITY SANITARY SEWER MAIN LINES SHALL BE A MINIMUM OF 8" IN DIAMETER. SERVICE LATERALS SHALL BE A MINIMUM OF 4" DIAMETER (RESIDENTIAL) OR A MINIMUM OF 6" DIAMETER (COMMERCIAL)
3. ALL GRAVITY SANITARY SEWER LINES SHALL BE PVC SDR 26.
4. MINIMUM ALLOWABLE SANITARY SEWER SLOPES ALLOWED ARE:
  - 8" PIPE 0.40%
  - 10" PIPE 0.28%
  - 12" PIPE 0.22%
5. SEWER LINE CONSTRUCTION SHALL BE ACCOMPLISHED BY THE USE OF A LASER INSTRUMENT UNLESS ANOTHER METHOD IS PREVIOUSLY APPROVED BY THE CITY.
6. THE CONTRACTOR SHALL AT ALL TIMES, DURING PIPE LAYING, DEWATER THE GROUND SUFFICIENTLY TO KEEP THE GROUNDWATER ELEVATION A MINIMUM OF 6" BELOW THE PIPE BEING LAID WITHIN THE AREA OF THE TRENCH.
7. ALL PIPES SHALL BE LAID ON A FIRM FOUNDATION. SOFT OR SPONGY BEDDING FOR PIPES WILL NOT BE ACCEPTED. ANY UNSUITABLE MATERIAL SHALL BE REMOVED AND REPLACED WITH A DRY, COMPACTED, GRANULAR MATERIAL SATISFACTORY TO THE CITY.
8. EXCAVATION AND BACKFILL: THE CONTRACTOR SHALL PROVIDE ADEQUATE SHEETING AND BRACING OF EXCAVATION WORK OR USE OF TRENCH BOX IN ORDER TO PROVIDE FOR THE SAFETY OF WORKMEN, AS WELL AS REPRESENTATIVES OF THE CITY, THE DESIGN ENGINEER, AND THE DEVELOPER.
9. THE CONTRACTOR SHALL INSTALL A METALLIZED FOIL LOCATER TAPE, OR SIMILAR DEVICE AS MAY BE APPROVED BY THE CITY FOR THE FULL LENGTH OF ALL PVC WATER, RECLAIMED WATER AND SEWAGE FORCE MAINS. THIS PIPE LOCATER AID SHALL BE INSTALLED (15) INCHES BELOW FINISHED GRADE OR AS DIRECTED BY THE MANUFACTURER AND IS IN ADDITION TO THE LOCATER WIRE REQUIRED IN THE UTILITY PIPE LOCATION MATERIALS DETAIL (MISCELLANEOUS DETAILS SECTION - M10).
10. MANHOLES SHALL BE LOCATED AT INTERVALS NOT EXCEEDING 400 FEET.
11. MANHOLE RIMS SHALL MATCH FLUSH WITH THE FINISH GRADE ELEVATION IN PAVED AREAS AND FLUSH WITH FINISH GRADE AND HAVE 4" THICK 3000 PSI CONCRETE POURED A MINIMUM OF 1.0' OUTSIDE OF THE COVER. CONCRETE IS TO BE POURED SQUARE.



STANDARD CONSTRUCTION DETAIL  
GENERAL NOTES  
SANITARY SEWER CONSTRUCTION

INDEX

S-1A

March 2022

## SANITARY SEWER CONSTRUCTION GENERAL NOTES

12. THE CONTRACTOR SHALL CONSTRUCT SANITARY SEWER MANHOLES IN SUCH A WAY THAT SEWER LINES DO NOT INTERSECT SEALED JOINTS BETWEEN SECTIONS OF THE MANHOLE.
13. RUBBER BOOTS AND STAINLESS STEEL BANDS SHALL BE UTILIZED IN THE CONNECTION OF THE SEWER MAIN TO THE MANHOLES (SEE RUBBER BOOT AND PRECAST JOINT CONNECTION DETAIL).
14. INDIVIDUAL SANITARY SERVICE CONNECTORS ON NEW CONSTRUCTION SHALL NOT BE CONNECTED DIRECTLY INTO MANHOLES, BUT TO SEWER MAIN LINES BY USE OF WYE CONNECTIONS.
15. FOR SINGLE FAMILY HOMES, SINGLE FOUR INCH MINIMUM SEWER SERVICES SHALL BE CONSTRUCTED AT EACH LOT OR UNIT AND LOCATED ON THE DOWNSTREAM SIDE OF THE LOT CENTER LINE. THESE SERVICES SHALL BE EXTENDED 4 FEET ABOVE GROUND AT THE PROPERTY LINE WITH A PVC RISER AND PLUG BEING EASILY VISIBLE FROM THE ROAD. RUBBER SEAL FITTINGS TO BE USED ON ALL LINES, NO GLUED JOINTS.
16. FOR MULTI-FAMILY AND COMMERCIAL SITES, SIX INCH MINIMUM SEWER SERVICES AND CLEANOUTS SHALL BE PROVIDED AS APPROVED BY THE CITY.
17. SANITARY SEWER LATERALS LONGER THAN 70 FEET, MEASURED FROM THE SEWER MAIN TO THE RIGHT-OF-WAY LINE MAY BE APPROVED ON A CASE BY CASE BASIS. SUCH LATERALS SHALL BE D.I.P. EPOXY LINED OR C-900 PVC.
18. SANITARY SEWER MANHOLES WHICH HAVE SEWER FORCE MAINS DISCHARGING DIRECTLY INTO THEM, OR ANY MANHOLE WITHIN 200 FEET OF A LIFT STATION, SHALL BE FIBERGLASS OR PVC LINED. RETRO-FITTING OF MANHOLES WITH LINERS SHALL BE REQUIRED WHEN NEW CONNECTIONS SUCH AS THIS ARE MADE. FIBERGLASS SHALL BE A MINIMUM 1/2" THICKNESS UNLESS APPROVED OTHERWISE BY THE CITY. LINING SHALL BE AGRU SURE-GRIP OR PRE-APPROVED EQUAL.
19. SEE CHART ON DETAIL INDEX S-1C FOR FORCEMAIN AND REUSE PIPE SIZE AND MATERIALS.
20. THE CITY REQUIRES THE DEVELOPER TO TELEWISE ANY AND ALL GRAVITY SANITARY SEWER MAIN LINES AND LATERALS PRIOR TO ANY FINAL ACCEPTANCE, AND RESERVES THE RIGHT TO REQUEST WATER AND AIR TESTING. THERE SHALL BE NO DIPS GREATER THAN 1" AS SEEN WITH A MANDREL TEST.
21. ALL GRAVITY SEWER MAINS PRIOR TO ACCEPTANCE BY THE CITY SHALL BE TELEVISED BY A REPUTABLE COMPANY THAT ENGAGES IN THIS TYPE OF WORK. TELEVISING IN ROAD SHALL BE AFTER BASE AND BEFORE PAVING. THE VIDEO SHALL BE NON-STOP WITH AUDIO DESCRIBING WHAT IS BEING REVIEWED. WRITTEN VIDEO LOGS DESCRIBING THE CONDITION OF THE LINES SHALL ACCOMPANY THE TAPE SUBMISSION TO THE CITY.
22. CONTRACTORS SHALL BE REQUIRED TO TELEWISE ALL GRAVITY SANITARY SEWER LINES IN THE PRESENCE OF CITY PERSONEL AND PROVIDE COPIES OF THE VIDEO TAPE TO THE PUBLIC UTILITY DEPT. ANY DEFECTS NOTED SHALL BE CORRECTED PRIOR TO ACCEPTANCE BY THE CITY.



STANDARD CONSTRUCTION DETAIL  
GENERAL NOTES  
SANITARY SEWER CONSTRUCTION

INDEX

S-1B

March 2022

## SANITARY SEWER CONSTRUCTION GENERAL NOTES

23. ALL GRAVITY SANITARY SEWER LINES WHICH ARE CONSTRUCTED OFF PUBLIC RIGHTS-OF-WAY WITHIN SIDEYARDS, BACKYARDS, AND OTHER POORLY ACCESSIBLE AREAS SHALL BE CONSTRUCTED OF C-900 PVC, OR EPOXY LINED DUCTILE IRON PIPE. ABSOLUTELY NO USE OF PLASTIC STYRENE FITTINGS SHALL BE ALLOWED.
24. SEWER LATERAL LOCATIONS SHALL BE MARKED ALONG THE OUTSIDE OF THE CURB WITH A SAWCUT S, AND BY A METAL TAB SET INTO THE PAVEMENT.
25. EZ-WRAP PLASTIC, AS MANUFACTURED BY PRESS-SEAL GASKET CORPORATION OR APPROVED EQUAL, SHALL BE USED ON THE OUTSIDE OF ALL MANHOLE AND WETWELL JOINTS. APPLY ONE LAYER OF 9" WRAP CENTERED ON EACH JOINT. A CITY INSPECTOR SHALL PERSONALLY INSPECT ALL JOINT SEALS PRIOR TO BACKFILLING OPERATIONS.
26. ALL PROPOSED GRAVITY SANITARY SEWER MAINS, 8" OR GREATER, SHALL BE FLUSHED AND CLEANED.
27. ALL GRAVITY SANITARY SEWER MAINS SHALL HAVE A MINIMUM COVER OF 36 INCHES. IN SPECIAL CASES WHERE IT IS IMPOSSIBLE OR INAPPROPRIATE TO PROVIDE ADEQUATE COVER. DUCTILE IRON CLASS 350 OR CONCRETE ENCASEMENT MAY BE USED AS APPROVED BY THE CITY.
28. SEWER FORCE MAINS SHALL BE PRESSURE TESTED AT 150 PSI STATIC PRESSURE FOR A PERIOD OF 2 HOURS. TESTS SHALL BE CONDUCTED BEFORE FINAL PAVING AND IN THE PRESENCE OF THE CITY'S INSPECTOR. MAXIMUM PRESSURE LOSS SHALL BE 5 PSI ON THE GAUGE.
29. ALL GRAVITY SANITARY SEWER PIPE SYSTEMS SHALL BE TELEVISED IN THE PRESENCE OF THE CITY INSPECTOR AND COPIES OF THE VIDEO AND WRITTEN REPORT SHALL BE SUBMITTED IN DVD FORMAT TO THE INSPECTOR AT LEAST FORTY EIGHT (48) HOURS PRIOR TO REQUESTING FINAL INSPECTIONS. ANY DEFECTS NOTED SHALL BE CORRECTED PRIOR TO ACCEPTANCE BY THE CITY.
30. ALL GRAVITY SANITARY SEWER PIPES, PRIOR TO ACCEPTANCE BY THE CITY, SHALL BE TELEVISED BY A REPUTABLE COMPANY THAT ENGAGES IN THIS TYPE OF WORK. THE VIDEO SHALL BE IN DVD FORMAT WITH HIGH QUALITY STANDARD RESOLUTION USING A CAMERA WITH SUITABLE LIGHTING TO ALLOW A CLEAR AND FOCUSED PICTURE OF THE ENTIRE INSIDE PIPE CIRCUMFERENCE. THE VIDEO SHALL BE NON-STOP WITH AUDIO DESCRIBING WHAT IS BEING VIEWED. WRITTEN LOGS DESCRIBING THE CONDITION OF THE LINES SHALL ACCOMPANY THE DVD SUBMISSION TO THE CITY.

### FORCE MAIN & REUSE MAIN STANDARDS

DIAMETER	MATERIAL	STANDARD
2" - 4"	PVC 1120 / SDR 21	ASTM D 2241
> 4" - 12"	PVC 1120 / DR18	AWWA C 900
14" - 36" ( 14" - 24" → DR - 18) ( 30" - 36" → DR - 18)	PVC 1120	AWWA C 905
ALL SIZES	HDPE (DIPS) DR 11	ASTM F 714

NOTE: PVC PIPE COLOR SHALL BE GREEN FOR SEWER FORCE MAIN, AND PURPLE FOR REUSE MAIN.



## STANDARD CONSTRUCTION DETAIL

### GENERAL NOTES

### SANITARY SEWER CONSTRUCTION

INDEX

S-1C

March 2022

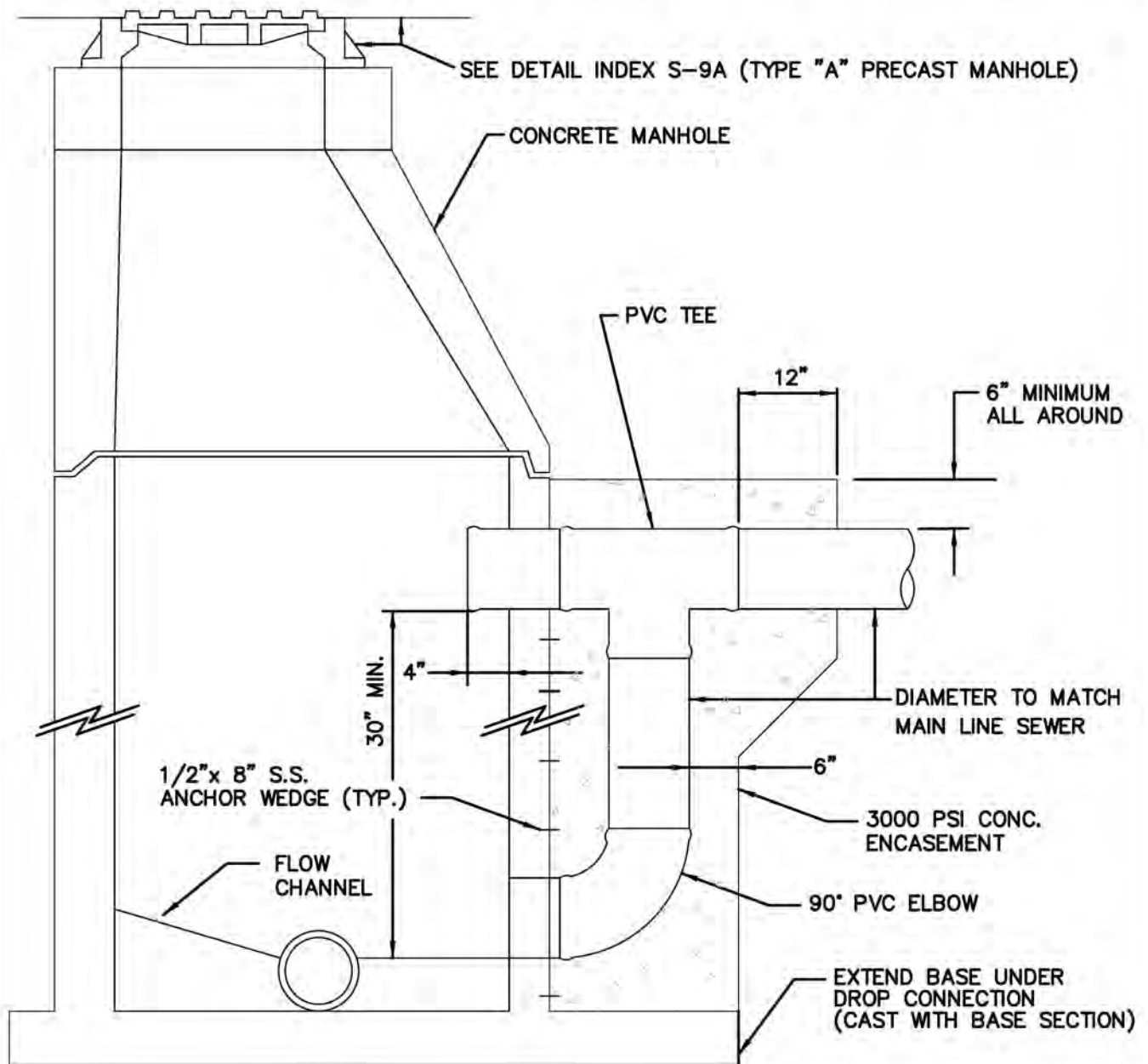

PROVIDE RUBBER GASKET PER A.S.T.M. C-923, CAST INTEGRALLY IN MANHOLE WALL AND LOCATED AS REQUIRED FOR 8" SANITARY SEWER

NOTE: FOR USE WHERE FREE DROP IS GREATER THAN 30". FOR GRAVITY SEWER AND FORCE MAINS.



STANDARD CONSTRUCTION DETAIL  
OUTSIDE DROP CONNECTION  
(FOR NEW MANHOLES)

NTS.

INDEX

S-2

March 2022

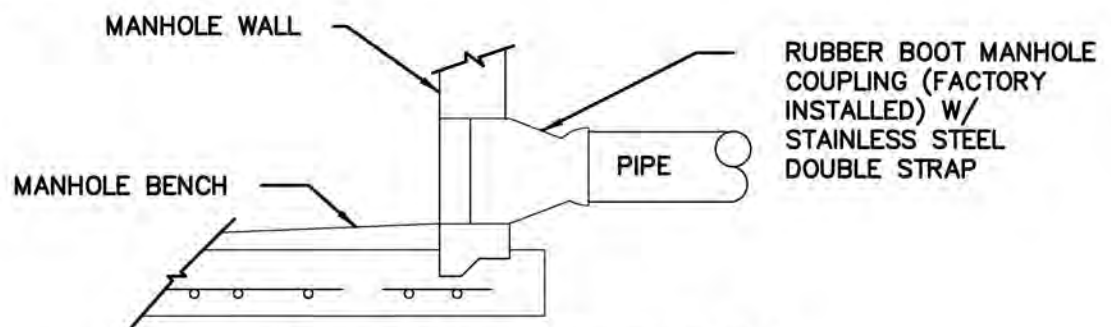
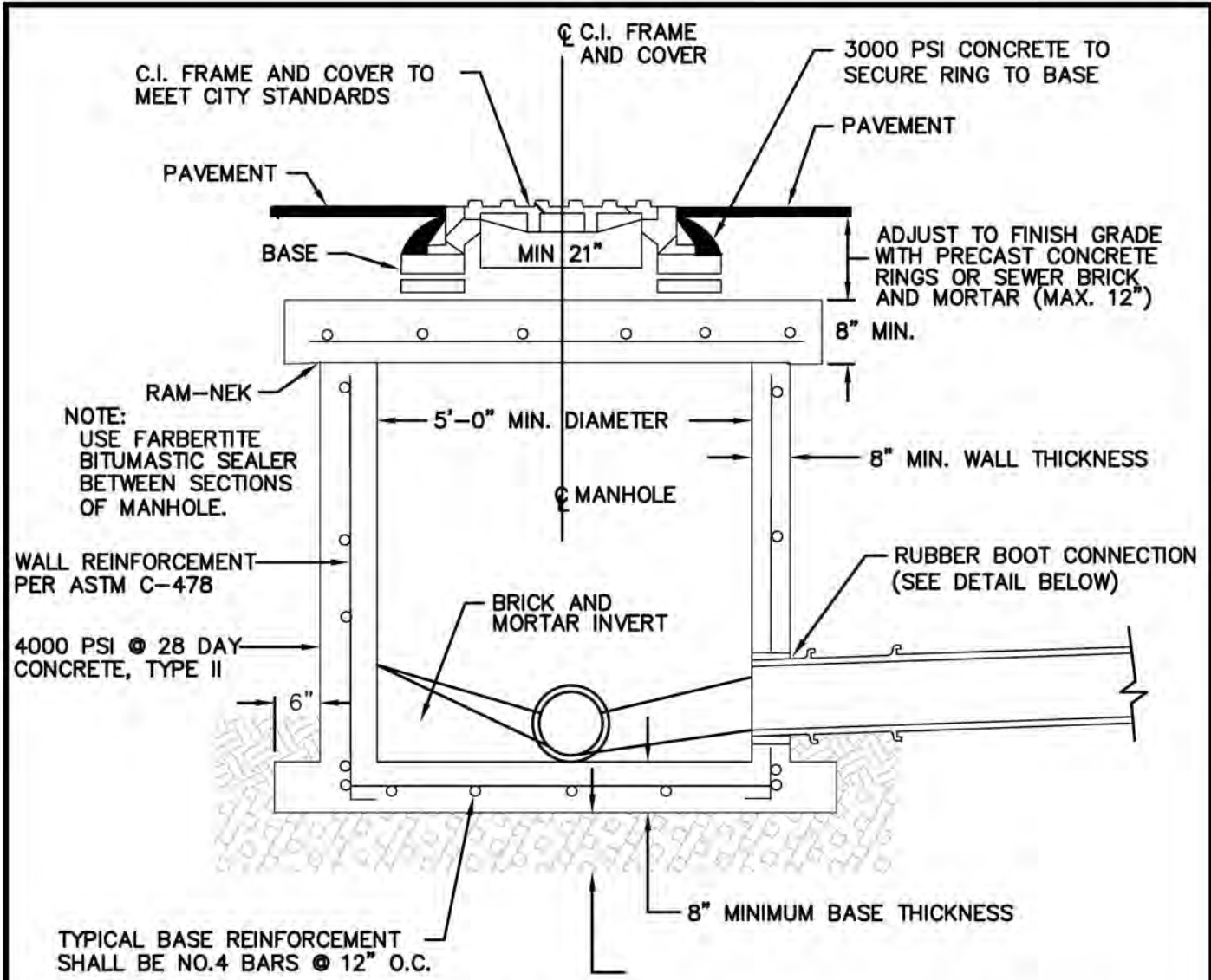

**RUBBER BOOT CONNECTION  
DETAIL**

USE FOR MANHOLES OF  
5'-0" OR LESS IN DEPTH



STANDARD CONSTRUCTION DETAIL  
SHALLOW MANHOLE  
NTS.

INDEX

S-3

March 2022

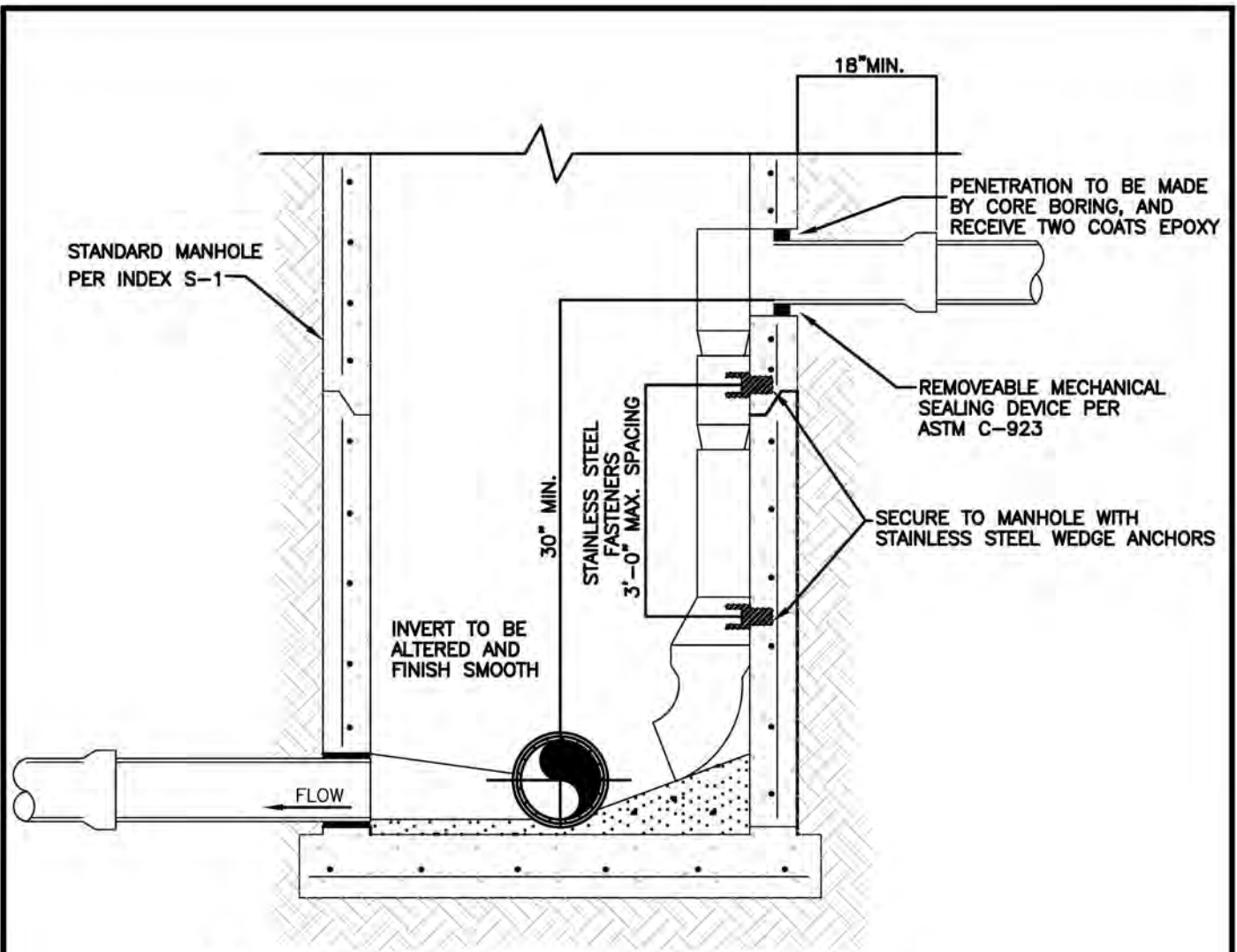

**NOTES:**

1. ALL PIPING ENTERING EXISTING STRUCTURES SHALL BE ACCOMPLISHED BY MECHANICAL ROTARY CORE BORING THE MANHOLE RISER. AFTER INSTALLATION OF PIPING, THE ANNULAR SPACE BETWEEN PIPING AND CONCRETE, SHALL BE SEALED WITH LINK-SEAL, THUNDERLINE SEALS, OR APPROVED EQUAL.
2. ALL FITTINGS SHALL BE SCH.40 PVC AS WELL AS DROP PIPE
3. FOR INSIDE DROPS UP TO 12" DIA USE INTRAFLOW LOW PROFILE INSIDE DROP SYSTEM AS MANUFACTURED BY ROYAL ENVIRONMENTAL SYSTEMS OR APPROVED EQUAL.
4. FOR INSIDE DROPS LARGER THAN 12" DIA ALL FERROUS MATERIALS SHALL BE FULLY COATED IN AND OUT WITH 2 COATS OF KOPPERS 300-M EPOXY 8 MILS DFT, TOGETHER WITH THE PENETRATION THROUGH THE STRUCTURE WALL STAINLESS STEEL SHALL NOT BE COATED.
5. ADAPTORS CONNECTING DIFFERENT PIPING MUST BE MANUFACTURED FOR THIS PURPOSE; SUBMIT DETAILS TO ENGINEER FOR APPROVAL.
6. FOR USE WHERE FREE DROP IS GREATER THAN 30". FOR GRAVITY SEWER AND FORCE MAINS.



**STANDARD CONSTRUCTION DETAIL**  
**INSIDE DROP CONNECTION**  
**(FOR EXISTING MANHOLES)**  
 NTS

INDEX

S-4

March 2022



FILL ANNULAR SPACE WITH EMBECO 167 MORTAR OR APPROVED EQUAL NON-SHRINK MORTAR (TYP.)

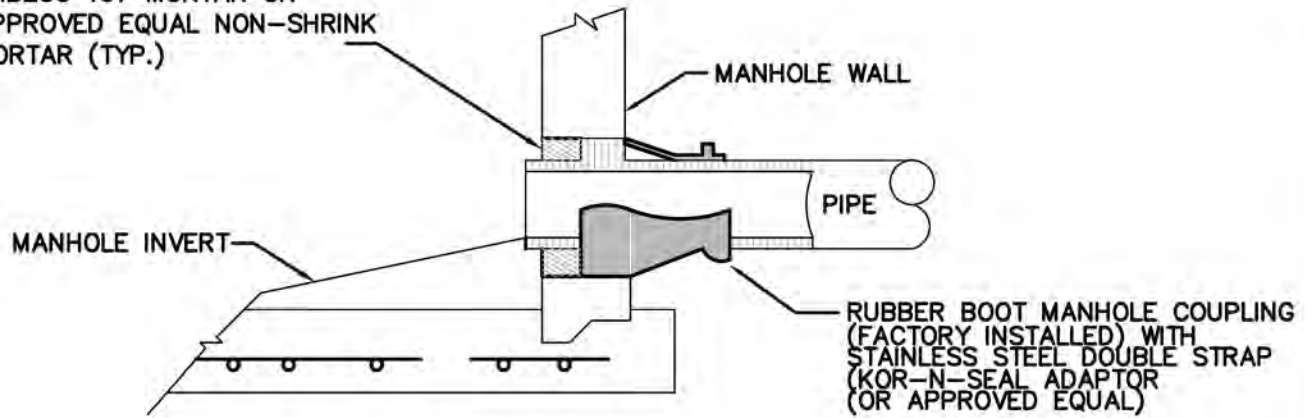

## MANHOLE PIPE CONNECTION

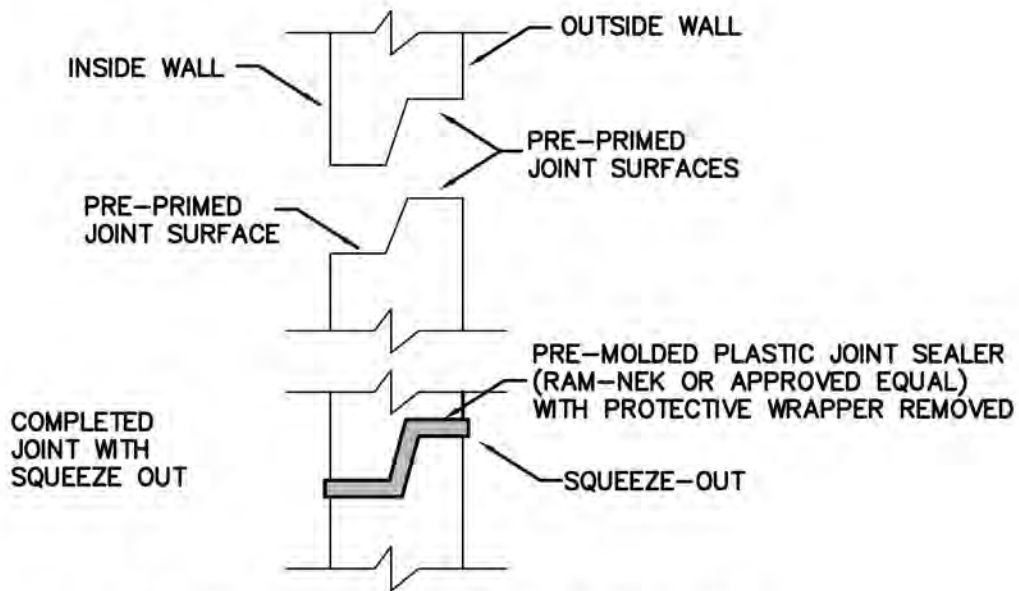

NOTE: ALL CONNECTIONS TO EXISTING SANITARY SEWER MANHOLES SHALL UTILIZE A CORING METHOD AND THE IN-FIELD INSTALLATION OF A RUBBER BOOT INTO THE MANHOLE AND THEN SECURED WITH A STAINLESS STEEL DOUBLE STRAP.

## PRECAST JOINT CONNECTION



STANDARD CONSTRUCTION DETAIL

RUBBER BOOT AND PRECAST JOINT CONNECTION DETAIL

NTS.

INDEX

S-5

March 2022

**SINGLE SERVICE - PLAN**

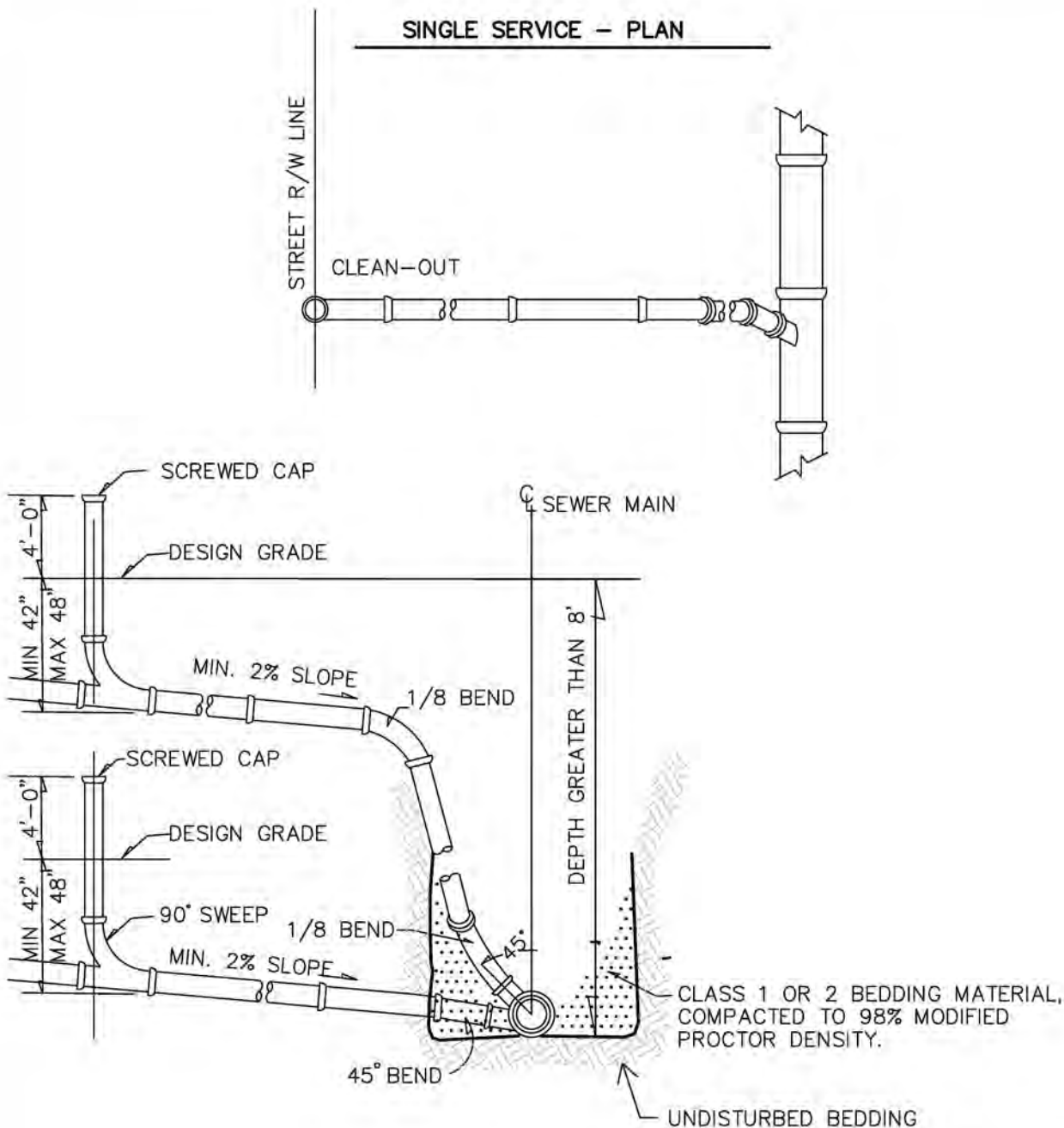

**SEWER LATERAL**

NOTE: USE OF STYRENE MATERIAL  
WILL NOT BE PERMITTED.

NOTE

SINGLE SERVICES SHALL BE MIN:  
6" DIA. COMMERCIAL  
AND 4" DIA. (MIN.) RESIDENTIAL

ALL JOINTS TO BE RUBBER  
GASKET (NO GLUED FITTINGS)



**STANDARD CONSTRUCTION DETAIL**

**SEWER LATERAL DETAIL**

NTS.

**INDEX**

**S-6**

**March 2022**

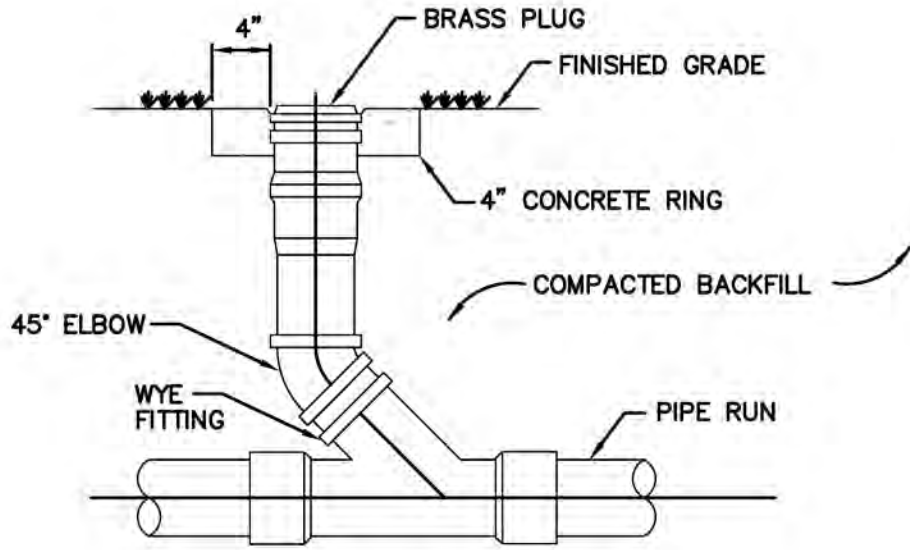

IN-LINE CLEANOUT

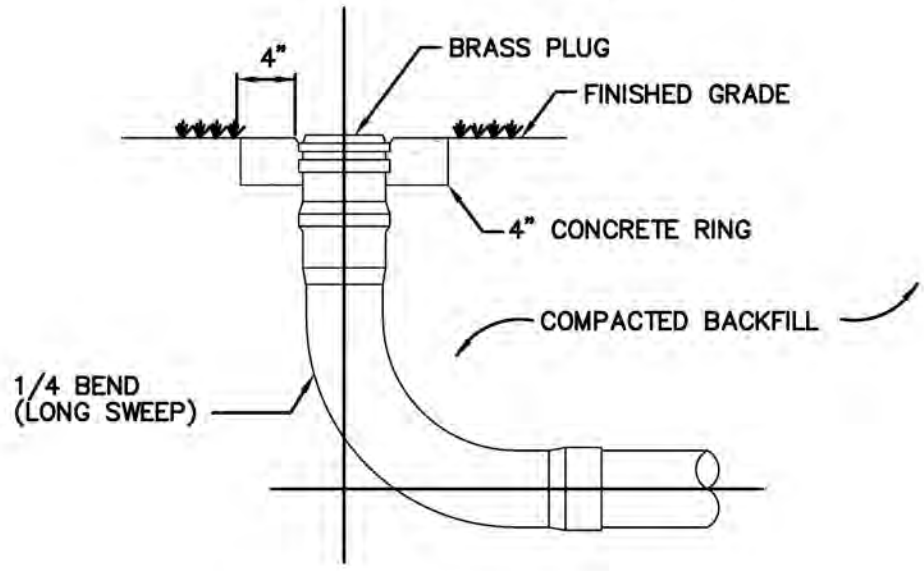

TERMINAL CLEANOUT

NOTE: CONCRETE COLLAR REQUIRED IN UNPAVED AREAS



STANDARD CONSTRUCTION DETAIL  
 CLEANOUT DETAIL  
 NTS.

INDEX

S-7

March 2022

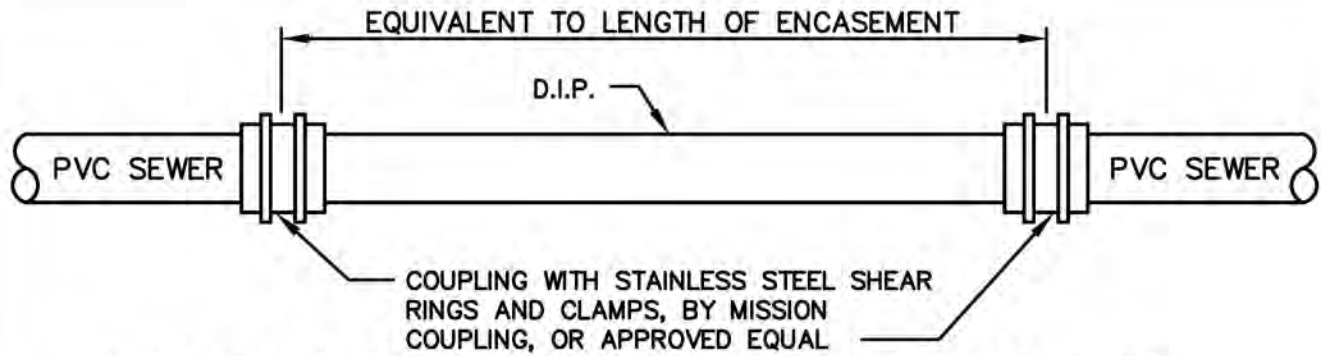

**DUCTILE IRON ALTERNATE TO CONCRETE SEWER ENCASEMENT**

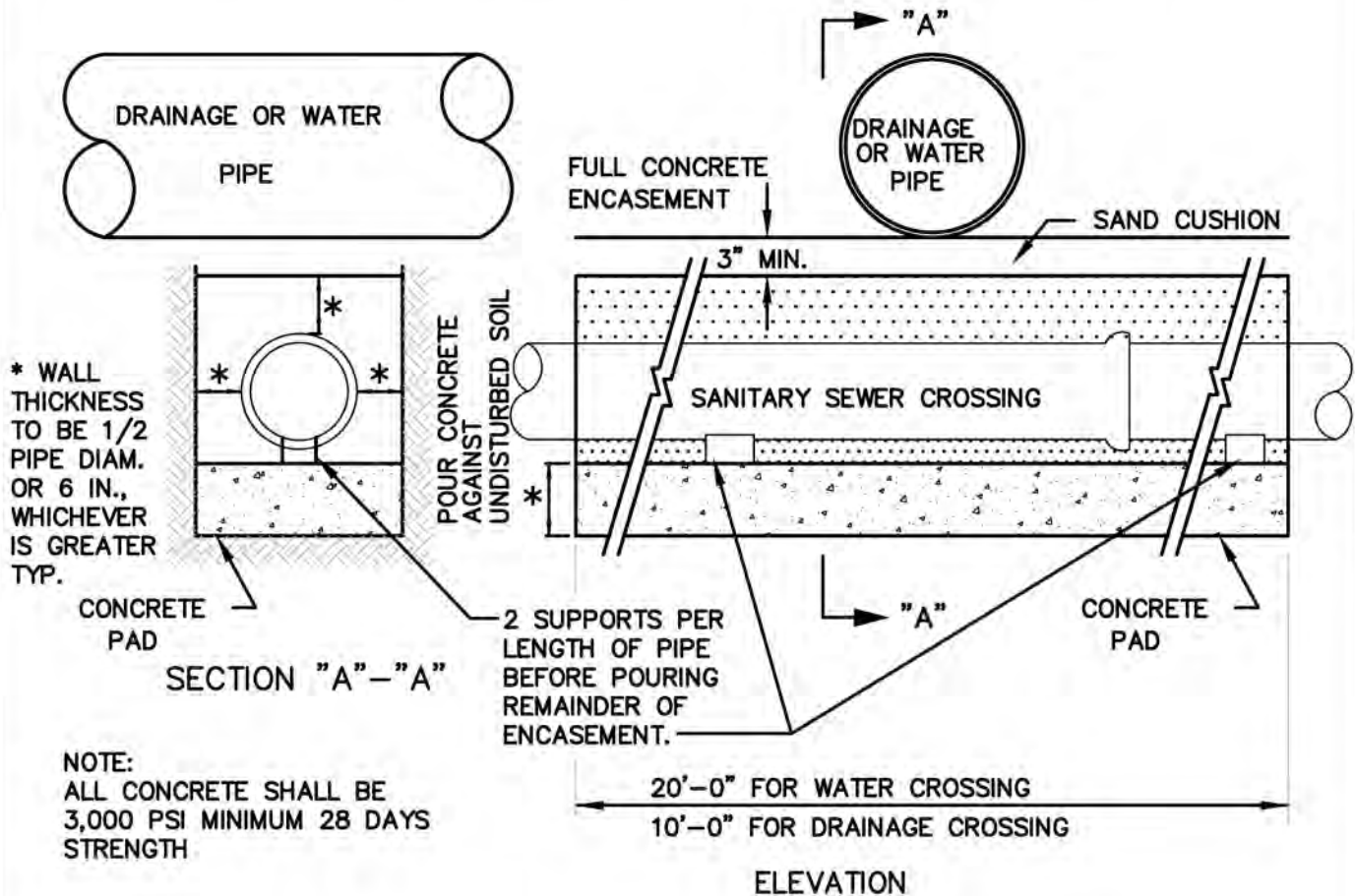

WATER MAIN SHALL BE LOCATED ABOVE ENCASEMENT AS SHOWN ON PLANS OR DETERMINED IN THE FIELD, USE ENCASEMENT WHERE VERTICAL CLEARANCE BETWEEN WATER MAIN AND SEWER IS LESS THAN 18 INCHES.



STANDARD CONSTRUCTION DETAIL  
SANITARY SEWER CROSSING  
NTS.

INDEX

S-8

March 2022

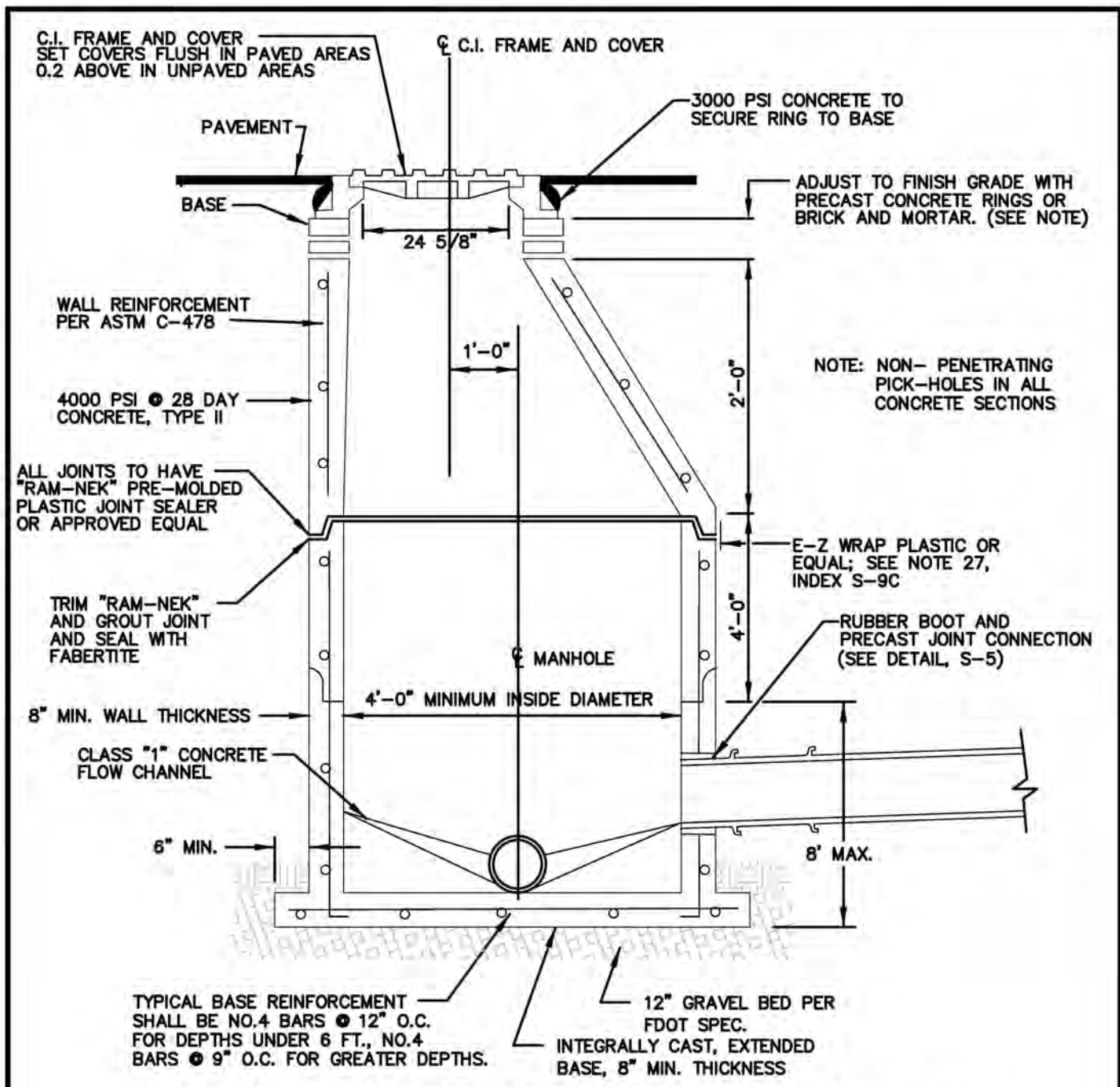

NOTES: 1. THE TOP OF THE CONE SHOULD BE SET 2 1/2" MIN. - 12" MAX. BELOW THE BOTTOM OF THE MANHOLE COVER FRAME TO ACCOMODATE FUTURE GRADE CHANGES (USE BRICK AND MORTAR OR PRECAST CONCRETE RINGS).

2. THE INTERIOR AND EXTERIOR SURFACES OF EACH CONCRETE MANHOLE, INCLUDING ADJUSTING RINGS, SHALL BE GIVEN TWO COATS (TOTAL DRY FILM THICKNESS OF 12 MILS) OF BITUMASTIC COATING, EXCEPT MANHOLES WHICH RECEIVE DISCHARGE FROM A FORCE MAIN AND ANY MANHOLES LOCATED WITHIN 200' OF A LIFT STATION OR ANY MANHOLES OUTSIDE OF THE RIGHT-OF-WAY. A SULFIDE CORROSION-RESISTANT MATERIAL SHALL BE USED AS LINER FOR THOSE MANHOLES THAT MEET THE CONDITIONS STATED ABOVE. THE LINER SHALL BE EITHER FIBERGLASS OR PVC OR AS APPROVED BY THE CITY.



STANDARD CONSTRUCTION DETAIL  
TYPE "A" PRECAST MANHOLE  
NTS

INDEX

S-9A

March 2022

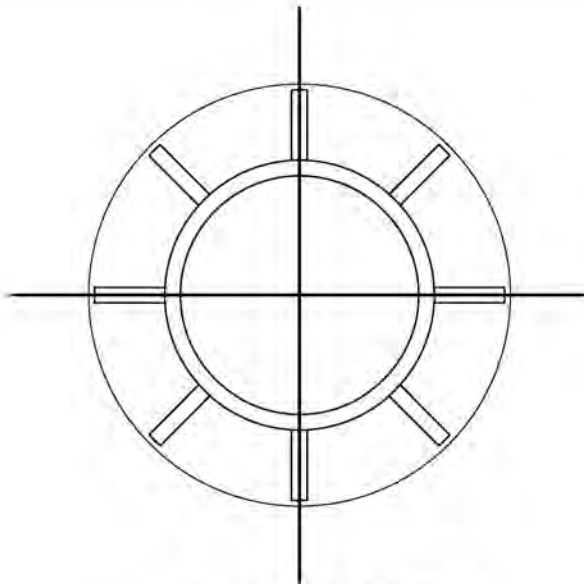

RING TOP VIEW

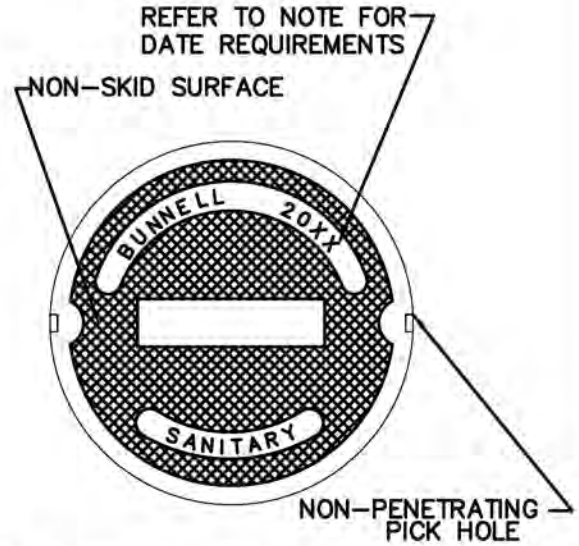

XX = USE CURRENT YEAR OF MANUFACTURE

COVER DETAIL

N.T.S.

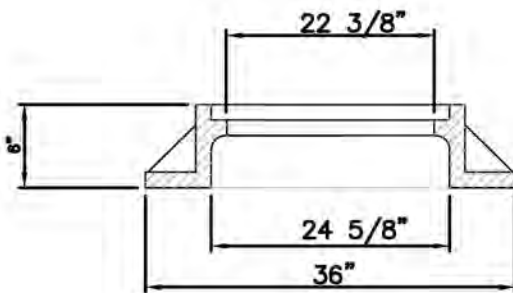

RING SECTION

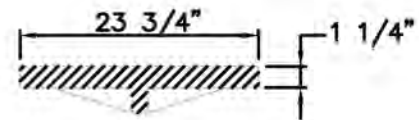

COVER SECTION

NOTE: MANHOLE RING AND COVER SHALL CONFORM TO FDOT STANDARD INDEX 201, SHEET 1 OF 6, AS SHOWN IN ROADWAY TRAFFIC DESIGN STANDARDS.

NOTE: YEAR STAMP TO MATCH CASTING YEAR

U. S. FOUNDRY 195E-ORS ("O" RING SEAL) OR APPROVED EQUAL

COVER TYPE	LOAD RATING	COVER WEIGHT	TOTAL WEIGHT
BJ	HEAVY DUTY	200	350

FOR MANHOLES IN FL. D.O.T. R/W OR AS DETERMINED BY THE CITY. THE COVER TYPE SHALL BE - BJ HEAVY DUTY 200 LBS W/ ORS.



STANDARD CONSTRUCTION DETAIL  
MANHOLE RING AND COVER DETAIL  
N.T.S.

INDEX

S-9B

March 2022

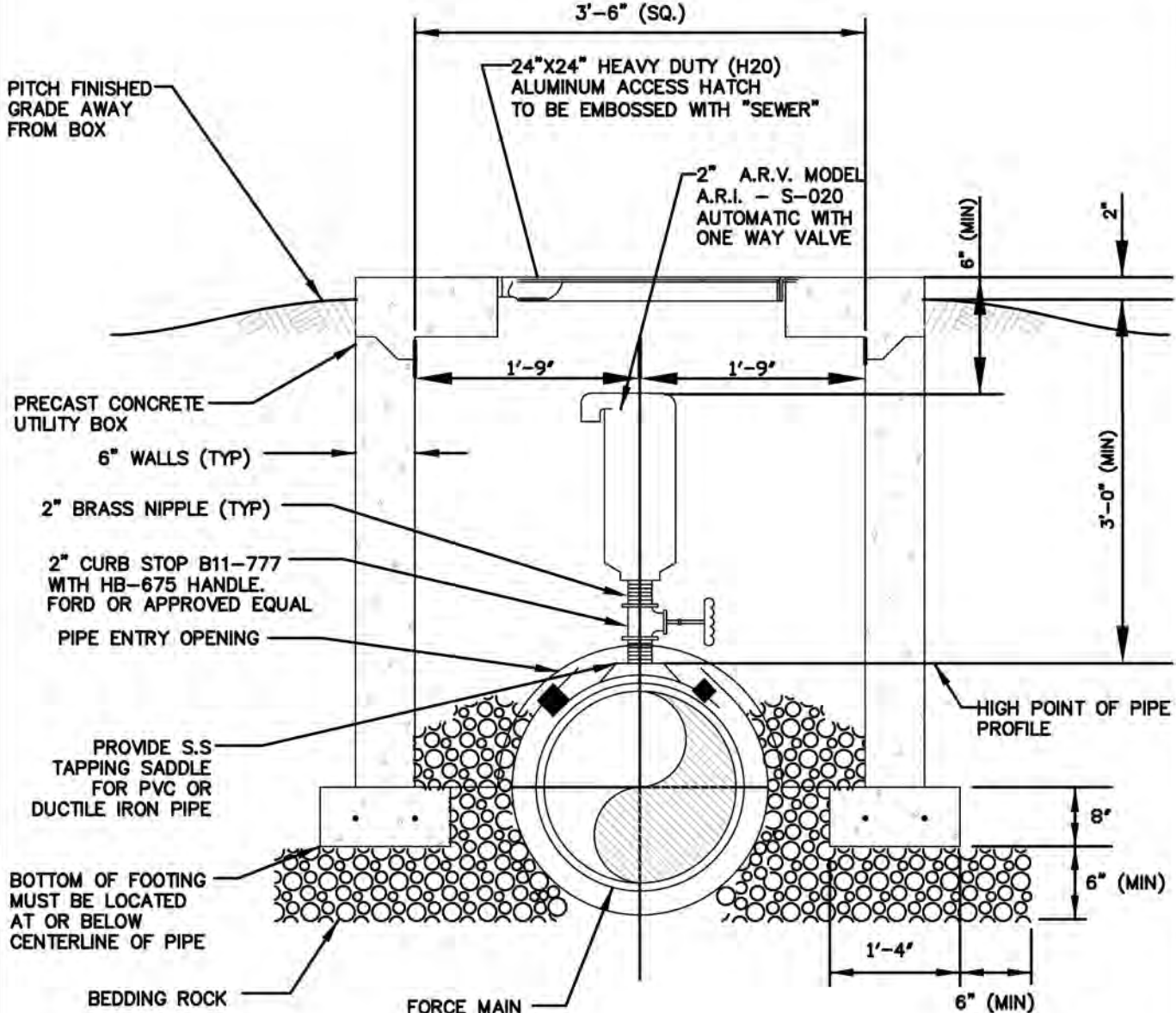

**NOTE:**

1. GALVANIZED PIPE AND FITTINGS NOT ACCEPTABLE FOR THIS INSTALLATION
2. STRUCTURE TO BE ADEQUATE FOR AASHTO H20 LOADING
3. DESIGNER IS RESPONSIBLE FOR PROVIDING CONSTRUCTION MATERIAL AND STEEL REINFORCING REQUIREMENTS
4. NO SURFACE COATING REQUIRED ON VAULT
5. ALUMINUM HATCH TO INCLUDE S.S. HINGE AND S.S. SLAM LOCKS WITH REMOVABLE KEYS
6. FITTINGS AND PIPE FOR A.R.V. SHALL BE BRASS



**STANDARD CONSTRUCTION DETAIL  
AUTOMATIC AIR RELEASE VALVE  
(FORCE MAIN)**

NTS

INDEX

S-10

March 2022

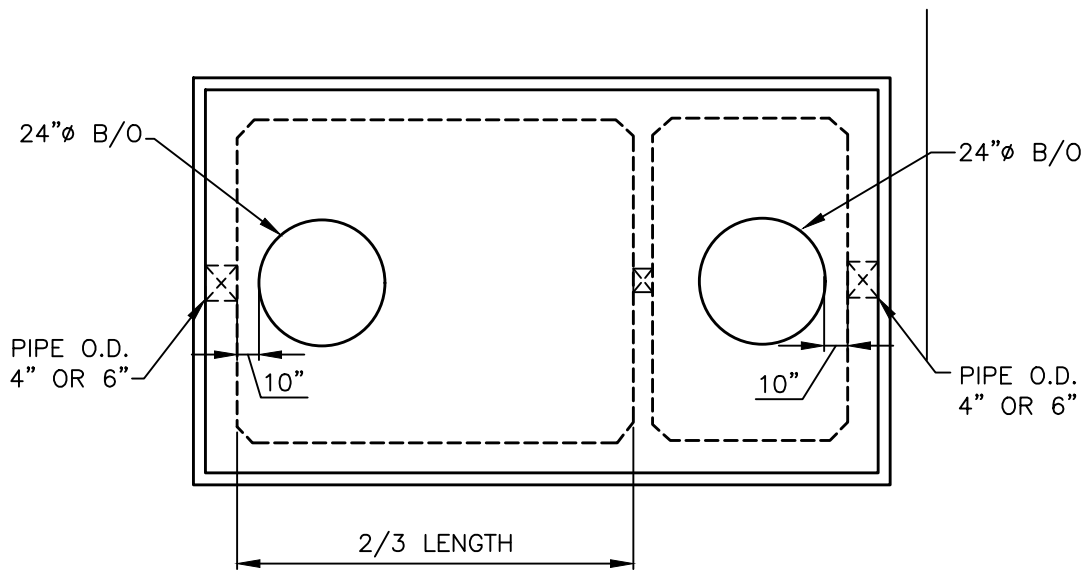

**PLAN VIEW**

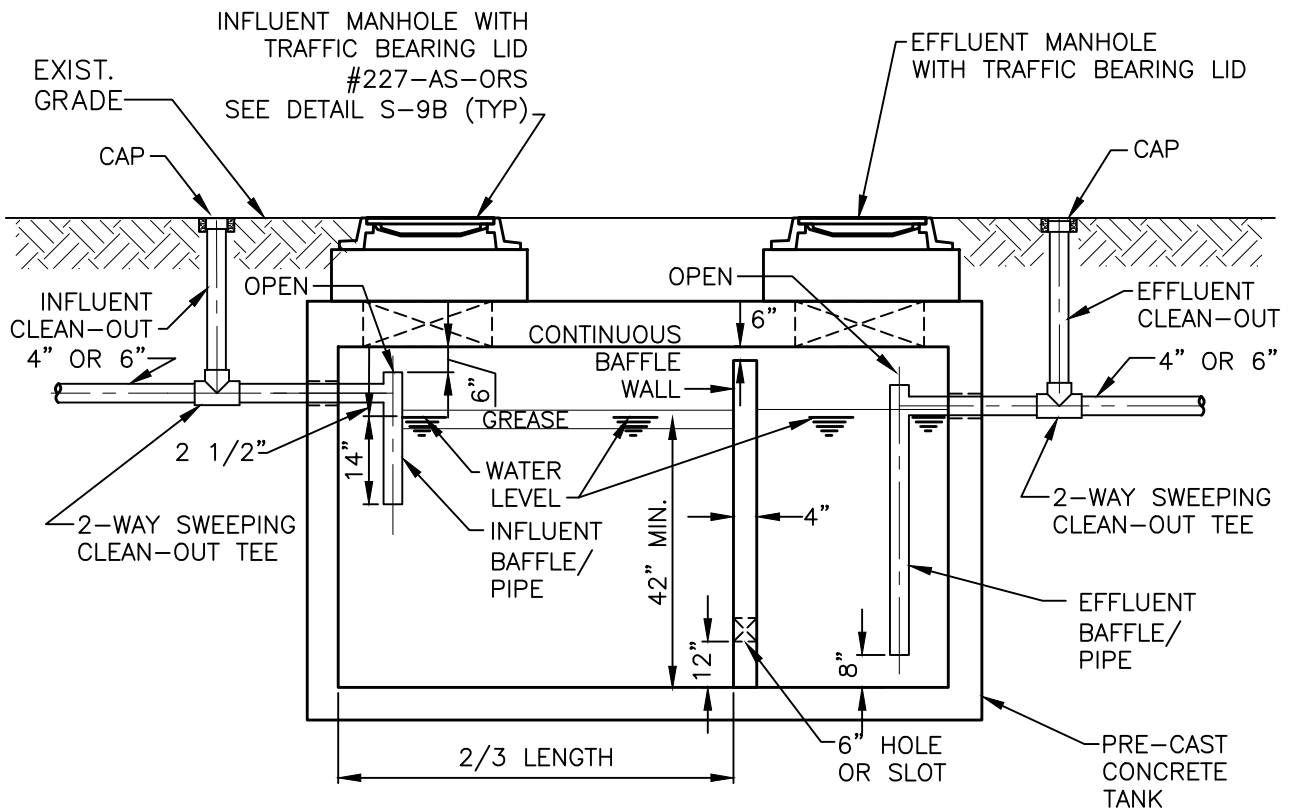

**SECTION**



**GREASE INTERCEPTOR DETAIL  
PLAN AND SECTION  
NTS.**

**INDEX**

**S-12A**

**March 2022**



**NOTES:**

1. GREASE INTERCEPTOR TANKS SHALL BE DESIGNED AND CONSTRUCTED TO MEET THE STRUCTURAL REQUIREMENTS OF FLORIDA ADMINISTRATIVE CODE CHAPTER 64E-6013. STANDARDS APPLY TO NEW CONSTRUCTION AND REMODELING.
2. THE CONTRACTOR OR ENGINEER OF RECORD SHALL PROVIDE THE CITY A COPY OF THE GREASE INTERCEPTOR(S) MANUFACTURER'S DETAILED SHOP DRAWING BEFORE APPROVAL FOR INSTALLATION.
3. GREASE INTERCEPTOR SIZING - THE EFFECTIVE CAPACITY OF EACH GREASE INTERCEPTOR IS DETERMINED ON A CASE-BY-CASE BASIS AND FORMULATED BY THE UTILITY DEPARTMENT. HOWEVER, THE MINIMUM GREASE INTERCEPTOR TANK VOLUME IS 750 GALLONS AND THE MAXIMUM IS 1,250 GALLONS. IF MORE THAN 1,250 GALLONS IS REQUIRED, THEN ADDITIONAL TANKS ARE INSTALLED IN SERIES FLOWING FROM ONE TO THE NEXT.
4. GREASE INTERCEPTOR TANKS SHALL BE INSPECTED UPON JOB SITE DELIVERY AND BEFORE INSTALLATION FOR STATE MANUFACTURING APPROVAL LEGEND OR DOCUMENTATION, DAMAGE, AND TANK EFFECTIVE CAPACITY BY THE CITY.
5. GREASE INTERCEPTORS APPROVED FOR INSTALLATION BY THE CITY SHALL BE INSTALLED ACCORDING TO THE STANDARDS AND SPECIFICATIONS.
6. GREASE INTERCEPTOR(S) SHALL BE LOCATED AS TO PROVIDE EASY ACCESS FOR ROUTINE INSPECTIONS, CLEANING AND MAINTENANCE AS REQUIRED BY CITY ORDINANCE AND MEET THE FOLLOWING MINIMUM REQUIREMENTS:
  - a. GREASE INTERCEPTORS SHALL BE TWO COMPARTMENTS (2/3 INLET; 1/3 OUTLET), CATEGORY FOUR (C4) TANKS AND CONSTRUCTED OF PRE-CAST CONCRETE OR APPROVED EQUIVALENT.
  - b. GREASE INTERCEPTORS SHALL HAVE A PROTECTIVE WATER-BASED COATING APPLIED TO THE INTERIOR AND EXTERIOR BY THE MANUFACTURER. THE EXTERIOR SHALL BE COATED TO A THICKNESS OF EIGHT (8) MILS, FOUR (4) MILS EACH COAT. THE INTERIOR SURFACES SHALL BE COATED TO A THICKNESS OF TWELVE (12) MILS, FOUR (4) MILS EACH COAT. THE COATING SHALL BE EQUIVALENT TO CONSEAL CS-55.
  - c. TANK WALLS SHALL BE A 4" THICK C4 PRE-CAST CONCRETE OR APPROVED EQUAL FOR ALL TANKS LOCATED IN GREEN (NON-TRAFFIC) AREAS. BOLLARDS OR SOME OTHER DEVICE SHALL BE PLACED AROUND THE TANK FOR PROTECTION. WALLS SHALL BE 6" THICK FOR ALL TANKS LOCATED IN TRAFFIC AREAS.
  - d. TANK BOTTOM SHALL BE A MINIMUM 4" THICK C4 PRE-CAST CONCRETE OR APPROVED EQUAL FOR ALL TANKS LOCATED IN GREEN AREAS. THE TANK BOTTOM SHALL BE 6" THICK FOR ALL TANKS LOCATED IN TRAFFIC AREAS.
  - e. TANK LIDS FOR TRAFFIC BEARING APPLICATIONS SHALL BE A MINIMUM 8" THICK WITH AN H-20 LOAD RATING. TANK LIDS FOR NON-TRAFFIC BEARING APPLICATIONS THAT ARE LOCATED IN GREEN AREAS SHALL BE A MINIMUM 6" THICK.
  - f. TANK BAFFLE WALLS SHALL BE A MINIMUM 4" THICK MONOLITHIC PRE-CAST CONCRETE CONSTRUCTION WITH A 6" FLOW THROUGH HOLE LOCATED 12" ABOVE THE FLOOR IN THE BAFFLE WALL.
  - g. ACCESS MANHOLES SHALL BE A MINIMUM 24" DIAMETER AND LOCATED OVER THE INLET AND OUTLET OF EACH INTERCEPTOR AND BROUGHT TO FINISHED GRADE IN PAVED AREAS AND 2" ABOVE FINISHED GRADE IN GREEN AREAS. THE MANHOLE COVER LIDS SHALL BE LABELED (GREASE INTERCEPTOR OR GREASE TRAP) AS TO IDENTIFY THE DEVICE.
  - h. TANK PLUMBING SHALL BE A MINIMUM FOUR-INCH DIAMETER SCHEDULE 40 PVC. FITTINGS SHALL NOT HAVE LEDGES, SHOULDERS OR REDUCTIONS CAPABLE OF RETARDING OR OBSTRUCTING FLOW IN THE PIPING. THE INLET PIPE INVERT SHALL ENTER THE TANK A MINIMUM OF 2-1/2" ABOVE THE TANK LIQUID LEVEL AND CONNECT TO A SANITARY TEE. A DROP PIPE SHALL BE CONNECTED TO THE INLET TEE AND EXTEND STRAIGHT DOWN, 14" BELOW LIQUID LEVEL. THE OUTLET PIPE SHALL CONNECT TO A SANITARY TEE WITH A DROP PIPE EXTENDING STRAIGHT DOWN FROM THE BOTTOM OF THE TEE TO 8" OFF THE TANK FLOOR.
  - i. TWO-WAY SWEEPING CLEANOUT TEES SHALL BE PROVIDED AT THE INLET (INFLUENT) AND OUTLET (EFFLUENT) ENDS OF EACH TANK AND BETWEEN TANKS IF IN SERIES. CLEANOUTS LOCATED IN TRAFFIC AREAS SHALL BE PROTECTED WITH THE INSTALLATION OF A CONCRETE BOX WITH METAL LID (ELEPHANTS FOOT).
  - j. ALL NEWLY INSTALLED GREASE INTERCEPTORS SHALL BE CLEANED OF ANY ACCUMULATION OF WATER, SILT, DEBRIS, OR FOREIGN MATTER OF ANY KIND AND BE FREE OF SUCH ACCUMULATION AT THE TIME OF FINAL INSPECTION.
  - k. UNDER THE SINK UNITS SHALL BE DEEMED GRANDFATHERED UNLESS UNIT IMPROVEMENTS EXCEED 50% OF VALUE.
7. GREASE INTERCEPTOR SHALL BE VENTED IN ACCORDANCE WITH CHAPTER 9 AND 10 OF THE FLORIDA BUILDING CODE - PLUMBING AT TIME OF INSTALLATION. INSPECTION OF VENTING SYSTEM REQUIRED BY CITY OF BUNNELL BUILDING DEPARTMENT PRIOR TO COVERING OR OTHERWISE CONCEALING GREASE INTERCEPTOR AND VENTING SYSTEM.



**GREASE INTERCEPTOR NOTES**  
**GENERAL NOTES**  
**NTS.**

**INDEX**

**S-12B**

**March 2022**

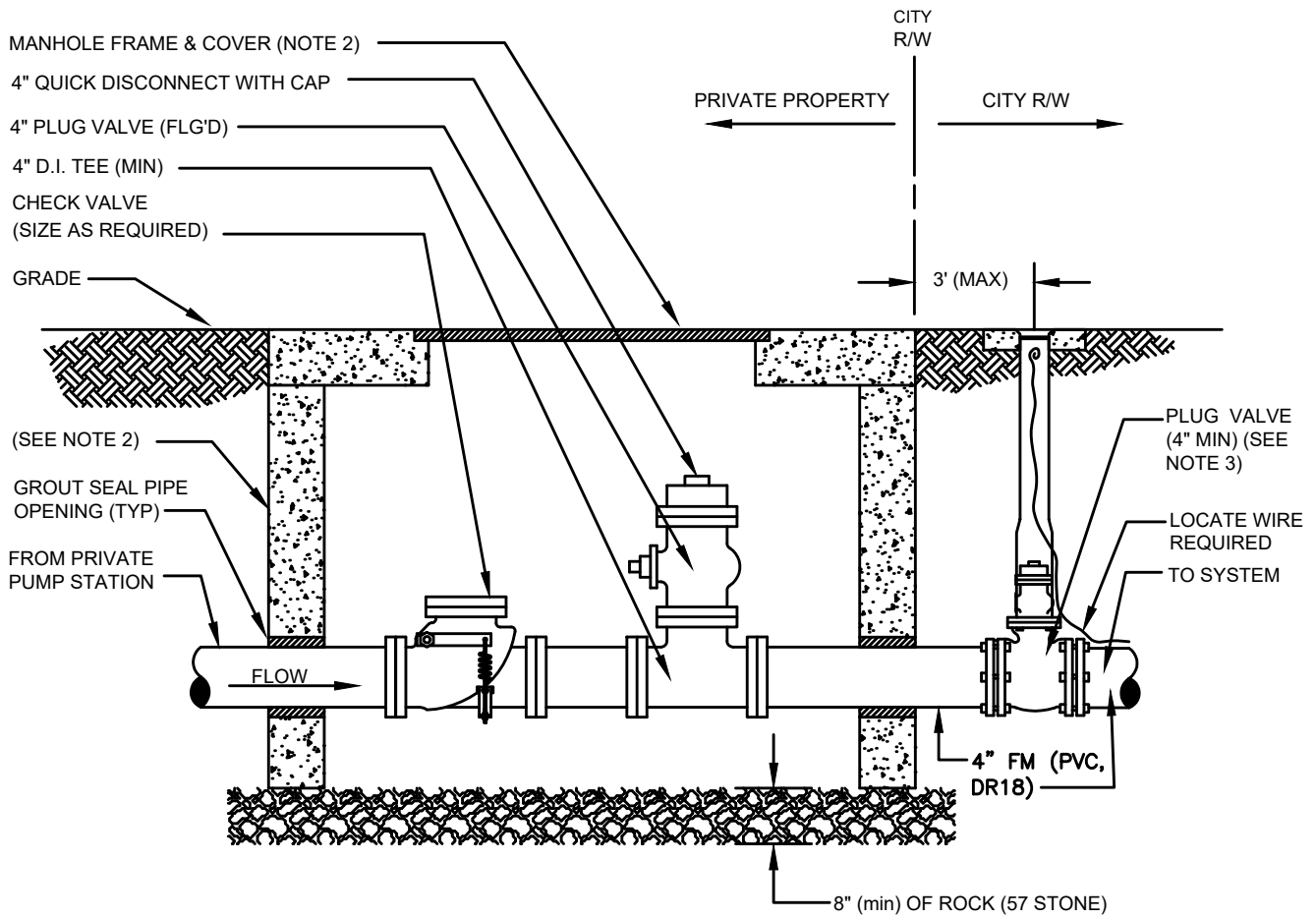

**NOTES :**

1. SEWER PUMP-OUT BOX SHALL BE CONSTRUCTED ON PRIVATE PROPERTY AND LOCATED AT THE R/W LINE. THE PREFERRED CONSTRUCTION LAYOUT IS SHOWN ABOVE.
2. ASSEMBLY TO BE ENCLOSED WITHIN A 48"x48" (MIN) PRECAST CONCRETE BOX WITH OPEN BOTTOM W/H-20 TRAFFIC LOADING COVER OR TYPE "C" MANHOLE OPEN BOTTOM WITH FRAME AND COVER (NON-LOGO TYPE COVER).
3. A CITY APPROVED PLUG VALVE (4" MIN) SHALL BE PROVIDED AT THE R/W LINE FOR ALL FORCE MAIN PIPING WHICH EXCEEDS 15' LINEAR FEET WITHIN THE CITY R/W AREA. THE PLUG VALVE AT THE R/W LINE IS NOT REQUIRED WHERE THE CONNECTION (CONNECTION AT CITY MAIN) IS LOCATED ON THE SAME SIDE OF THE STREET AS THE PUMP-OUT BOX (SHORT-SIDE SERVICE) AND CONSIST OF 15 LINEAR FEET OR LESS WITHIN THE CITY R/W AREA.
4. NO CONNECTIONS PERMITTED INTO CITY FORCE MAINS WHICH ARE GREATER THAN 12" SIZE UNLESS THE CONNECTION IS FROM A MASTER PUMP STATION (441GPM, MIN.)
5. QUICK DISCONNECT WITH CAP SHALL BE ALUMINUM AND BE POSITIONED DIRECTLY UNDER MANHOLE LID FOR ACCESS.



**STANDARD CONSTRUCTION DETAIL  
PRIVATE PUMP-OUT  
DETAIL ASSEMBLY**

NTS.

INDEX

S-13

March 2022

IN ORDER TO ENSURE THAT NEW DEVELOPMENTS WITHIN THE CITY ARE CONSTRUCTED SUBSTANTIALLY IN ACCORDANCE WITH CITY REGULATIONS AND THE APPROVED DRAWINGS, THE FOLLOWING INFORMATION IS REQUIRED ON ALL PAVING AND DRAINAGE "AS-BUILT" DRAWINGS:

1. PAVEMENT AND CURB WIDTHS SHALL BE VERIFIED AND DIMENSIONED FOR EACH STREET AT EACH BLOCK. ALL RADII AT INTERSECTIONS SHALL BE VERIFIED AND DIMENSIONED. THIS INFORMATION TO CLEARLY INDICATE IT AS BEING "AS-BUILT" INFORMATION.
2. ROADWAY ELEVATIONS SHALL BE RECORDED AT ALL GRADE CHANGES OR OTHER INTERVALS AS NEEDED ALONG ALL STREETS. STREET CENTERLINE AND CURB INVERT ELEVATIONS SHALL BE RECORDED AS NOTED. THE "AS-BUILT" CENTERLINE PROFILE OF ALL STREETS SHALL ALSO BE SHOWN ON THE PLAN AND PROFILE SO IT MAY BE COMPARED TO THE EXISTING AND DESIGNED PROFILE GRADE LINES. ALL STREET CENTERLINES ON "AS-BUILTS" SHALL BE LABELED WITH STREET NAME AND RIGHT-OF-WAY WIDTH ON EVERY PAGE.
3. STORM DRAINAGE STRUCTURES SHALL BE LOCATED AND/OR DIMENSIONED FROM CENTERLINES OR LOT LINES AS APPROPRIATE.
4. STORM DRAINAGE PIPE INVERT AND STRUCTURE TOP AND BOTTOM ELEVATIONS SHALL BE RECORDED AND CLEARLY DENOTED AS "AS-BUILT" INFORMATION. DESIGN ELEVATIONS SHALL BE CROSSED OUT AND AS-BUILT INFORMATION WRITTEN NEXT TO IT.
5. STORM DRAINAGE PIPE MATERIAL, LENGTH, AND SIZE SHALL BE MEASURED AND/OR VERIFIED. THIS INFORMATION TO CLEARLY INDICATE IT AS BEING "AS-BUILT" INFORMATION.
6. ALL APPLICABLE TOPOGRAPHIC INFORMATION, PERTINENT TO THE ON SITE DRAINAGE SYSTEM SUCH AS DITCHES, LAKES, CANALS, ETC. THAT ARE DEEMED APPROPRIATE BY THE CITY SHALL BE NOTED. NORMALLY, RECORDING ELEVATIONS EVERY 100 FEET AT THE TOP OF BANK AND TOE OF SLOPE WILL BE REQUIRED. MEASUREMENTS SHALL BE TAKEN AND RECORDED IN ORDER TO ACCURATELY TIE DOWN THESE FEATURES TO THE ROADWAY CENTERLINES AND TO PLAT LINES. WHENEVER POSSIBLE, CONTOUR LINES SHALL BE UTILIZED TO GRAPHICALLY DESCRIBE THESE TOPOGRAPHIC FEATURES.
7. RETENTION AREAS SHALL HAVE THEIR TOP-OF-BANK AND BOTTOM ELEVATIONS RECORDED. ACTUAL MEASUREMENTS SHALL BE TAKEN AND DIMENSIONS RECORDED OF THE SIZE OF ALL RETENTION AREAS. MEASUREMENTS SHALL BE DONE FROM TOP-OF-BANK TO TOP-OF-BANK WITH SIDE SLOPES INDICATED. SEPARATE CALCULATIONS SHALL BE SUBMITTED TO INDICATE REQUIRED AND PROVIDED RETENTION VOLUMES.
8. STORM DRAINAGE SWALE CENTERLINES SHALL BE LOCATED AND ELEVATIONS OF FLOW LINE SHALL BE RECORDED EVERY 100 FEET.
9. ANY SPECIAL FEATURES SUCH AS CONCRETE FLUMES, LAKE BANKS, WALLS, FENCING, ETC., WHICH WERE A PART OF THE APPROVED CONSTRUCTION DRAWINGS SHOULD ALSO BE LOCATED AND DIMENSIONED.
10. SUBMIT CERTIFIED PAPER PRELIMINARY "AS-BUILTS" WITH REQUEST FOR FINAL INSPECTION. SUBMIT 3 SETS SHOWING STREET AND DRAINAGE FACILITIES. FOLLOWING FINAL INSPECTION AND COMMENTS, CONTRACTOR SHALL REVISE AS-BUILTS TO ADDRESS CITY COMMENTS AND SUBMIT 3 SETS CERTIFIED FINAL "AS-BUILTS". ALL "AS-BUILT" DRAWINGS SHALL BE CERTIFIED BY A REGISTERED LAND SURVEYOR AND CERTIFIED THAT THEY HAVE BEEN REVIEWED BY ENGINEER OF RECORD. PROVIDE A CD OF AUTOCAD DRAWINGS AND PDF FILES OF EACH INDIVIDUAL SHEET (CITY TO APPROVE THE VERSION OF AUTOCAD). AS-BUILTS SHALL BE IN STATE PLANE COORDINATES. HORIZONTAL COORDINATES SHALL BE IN NAD 1983 AND VERTICAL COORDINATES IN NAVD 1988.



**STANDARD CONSTRUCTION DETAIL  
REQUIREMENTS FOR "AS-BUILT" DRAWINGS  
(PAVING & DRAINAGE)**

INDEX

M-1A

March 2022

IN ORDER TO ENSURE THAT NEW DEVELOPMENTS WITHIN THE CITY ARE CONSTRUCTED SUBSTANTIALLY IN ACCORDANCE WITH CITY REGULATIONS AND THE APPROVED DRAWINGS, THE FOLLOWING INFORMATION IS REQUIRED ON ALL WATER AND SEWER "AS-BUILT" DRAWINGS:

1. SANITARY SEWER MANHOLES SHALL BE VERIFIED AND DIMENSIONED FROM STREET CENTERLINES OR LOT LINES AS APPROPRIATE. ALL RIM AND INVERT ELEVATIONS SHALL BE VERIFIED AND RECORDED. THIS INFORMATION TO CLEARLY INDICATE IT AS BEING AS-BUILT INFORMATION.
2. SANITARY SEWER LINE LENGTHS, SIZES, MATERIAL, SLOPE, ETC., SHALL BE VERIFIED AND RECORDED. THIS INFORMATION TO CLEARLY INDICATE IT AS BEING AS-BUILT INFORMATION.
3. SEWER LATERALS SHALL BE VERIFIED AND RECORDED AT THEIR CLEAN-OUT LOCATIONS. STATIONING AND OFFSET DISTANCES SHALL BE MEASURED FROM DOWNSTREAM MANHOLES TOWARDS UPSTREAM MANHOLES.
4. LIFT STATIONS AND FORCE MAINS SHALL BE VERIFIED AND DIMENSIONED FROM STREET CENTERLINES OR LOT LINES AS APPROPRIATE. FORCE MAIN DEPTH AND LOCATION INCLUDING VALVES WILL BE PROVIDED AND TIED TO PERMANENT ABOVE GRADE FEATURES EVERY 500 FEET. DIMENSIONAL AND ELEVATION INFORMATION INDICATED ON THE APPROVED PLAN SHALL BE VERIFIED AND RECORDED. THIS INFORMATION TO CLEARLY INDICATE IT AS BEING AS-BUILT INFORMATION. BURIED ELECTRICAL SERVICE LINE SHALL BE CLEARLY DIMENSIONED, LOCATED AND LABELED.
5. CURB CUTS OR METAL TABS, USED TO MARK SEWER LATERALS, WATER SERVICES AND WATER VALVES, SHALL BE VERIFIED FOR PRESENCE AND ACCURACY OF LOCATION.
6. WATER MAIN LINES SHALL BE DIMENSIONED OFF THE BACK OF CURB OR EDGE OF PAVEMENT IF NO CURB IS PRESENT. WATER MAIN LINE MATERIAL, SIZE, LENGTH AND DEPTH PLACED SHALL ALSO BE NOTED. THIS INFORMATION TO CLEARLY INDICATE IT AS BEING AS-BUILT INFORMATION.
7. WATER VALVES, TEES, ALL SERVICES, BLOW-OFFS AND FIRE HYDRANTS SHALL BE LOCATED BY TYING THEM TO SANITARY SEWER MANHOLES. STATIONING AND OFFSET DISTANCES SHALL BE MEASURED FROM DOWNSTREAM MANHOLES TO UPSTREAM MANHOLES.
8. SUBMIT CERTIFIED PAPER PRELIMINARY "AS-BUILTS" WITH REQUEST FOR FINAL INSPECTION. SUBMIT 3 SETS SHOWING WATER FACILITIES AND 3 WITH SEWER FACILITIES. FOLLOWING FINAL INSPECTION AND COMMENTS, CONTRACTOR SHALL REVISE AS-BUILTS TO ADDRESS CITY COMMENTS AND SUBMIT 3 SETS CERTIFIED FINAL "AS-BUILTS".(5 SETS FOR SUBDIVISIONS) ALL "AS-BUILT" DRAWINGS SHALL BE CERTIFIED BY A REGISTERED LAND SURVEYOR AND ENGINEER OF RECORD. PROVIDE A CD OF AUTOCAD DRAWINGS AND PDF FILES OF EACH INDIVIDUAL SHEET.

NOTE: REFERENCES TO WATER SHALL MEAN BOTH POTABLE AND RECLAIMED WATER.



STANDARD CONSTRUCTION DETAIL  
 REQUIREMENTS FOR AS BUILT DRAWINGS  
 (WATER & SEWER)

INDEX

M-1B

March 2022

GENERAL NOTES:

1. ALL CONSTRUCTION SHALL BE IN ACCORDANCE WITH THE CITY LAND DEVELOPMENT CODE REQUIREMENTS, AND THE MINIMUM STANDARD CONSTRUCTION DETAILS AND CONSTRUCTION SPECIFICATIONS. AN ENGINEERING PERMIT AND TREE REMOVAL PERMIT IS REQUIRED PRIOR TO STARTING CONSTRUCTION.
2. NO LAND SHALL BE CLEARED, EXCAVATED OR FILLED AND NO STRUCTURE SHALL BE ERECTED, REPAIRED OR DEMOLISHED WITHOUT PROPER PERMIT(S) AS REQUIRED BY THE CITY.
3. NOTIFY THE CITY UTILITY DIVISION AT (386)437-7515 48 HOURS PRIOR TO THE START OF CONSTRUCTION.
4. ANY CONSTRUCTION CHANGES TO APPROVED PLANS SHALL BE SUBMITTED TO THE CITY FOR APPROVAL PRIOR TO PERFORMING THE WORK.
5. ROAD CONSTRUCTION AND PIPE INSTALLATION COMPACTION AND DENSITY TESTING SHALL CONFORM TO THE CITY MINIMUM REQUIREMENTS. CERTIFIED COPIES OF TEST REPORTS SHALL BE SUBMITTED TO THE CITY INSPECTOR AND THE CITY'S ENGINEERING DIVISION.
6. A PRE-PAVING UTILITY INSPECTION MUST BE REQUESTED AND COMPLETED PRIOR TO THE PAVING OF ALL ROADS, STREETS, AND PARKING AREAS.
7. A FINAL INSPECTION, TO BE CONDUCTED BY THE CITY, SHALL BE PERFORMED ON ALL CONSTRUCTION. THE DESIGN ENGINEER SHALL NOTIFY THE CITY UTILITY DIVISION AT (386)437-7515 WHEN REQUESTING A FINAL INSPECTION.
8. THREE COMPLETE SETS OF AS-BUILT DRAWINGS (5 FOR SUBDIVISIONS) ARE REQUIRED TO BE SUBMITTED TO THE CITY PRIOR TO REQUESTING A FINAL INSPECTION.
9. CONSTRUCTION SITES THAT DISTURB ONE ACRE OR MORE WILL BE REQUIRED TO SEEK COVERAGE UNDER THE GENERIC PERMIT FOR STORMWATER DISCHARGE FROM LARGE AND SMALL CONSTRUCTION ACTIVITIES. IN ACCORDANCE WITH THIS REQUIREMENT, A STORMWATER POLLUTION PREVENTION PLAN (SWPP) MUST BE SUBMITTED TO THE CITY'S UTILITY DIVISION PRIOR TO CONSTRUCTION TO BE IN COMPLIANCE WITH THE PERMIT.
10. CONTRACTOR WILL FOLLOW REQUIRED WASTE MANAGEMENT PRACTICES
11. SEEDING OR SODDING SHALL BE INITIATED FOR EROSION AND SEDIMENT CONTROL ON DISTURBED AREAS AS SOON AS PRACTICABLE IN PORTIONS OF THE SITE WHERE CONSTRUCTION ACTIVITIES HAVE TEMPORARILY OR PERMANENTLY CEASED.
12. ANY FIELD MODIFICATIONS OR DEVIATIONS TO THE CONSTRUCTION PLANS REQUIRE WRITTEN APPROVAL BY BOTH THE ENGINEER OF RECORD AND THE CITY UTILITY DIVISION.
13. ANY DIRECTIONAL BORES WILL BE PER SECTION 555 OF FDOT STANDARD SPECIFICATIONS (LATEST EDITION)



STANDARD CONSTRUCTION DETAIL  
GENERAL CONSTRUCTION NOTES

INDEX

M-2

March 2022

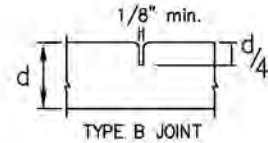
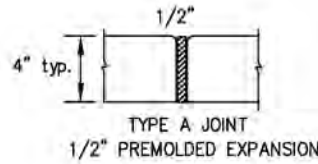
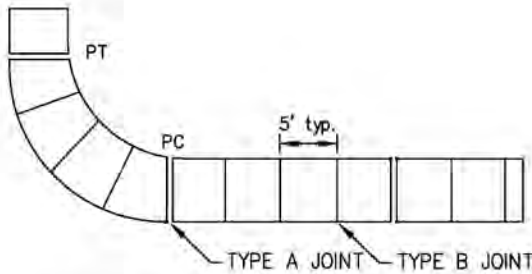

1. SIDEWALKS, BIKEPATHS, RAMPS, AND DRIVEWAY APRONS SHALL BE CONSTRUCTED OF PLAIN PORTLAND CEMENT CONCRETE WITH A MAXIMUM SLUMP OF 6 +/- 1 INCHES, A MINIMUM DEVELOPED COMPRESSIVE STRENGTH OF 3000 P.S.I. IN 28 DAYS, AND A MINIMUM UNIFORM THICKNESS OF 4 INCHES WHERE INTENDED SOLELY FOR PEDESTRIAN TRAFFIC, AND 6 INCHES THICK WHERE MOTOR VEHICLES ARE LIKELY TO CROSS. SIDEWALKS SHALL BE 5 FOOT WIDE UNLESS OTHERWISE SHOWN ON PLANS.
2. SIDEWALKS AND BIKE PATHS SHALL BE PLACED PARALLEL TO, AND ONE FOOT WITHIN THE RIGHT-OF-WAY LINE EXCEPT THAT THE CITY MAY APPROVE DEVIATIONS TO SAVE SPECIMEN TREES PROVIDED THAT THE PAVEMENT REMAINS WITHIN THE RIGHT-OF-WAY, IS NOT DIMINISHED IN WIDTH, AND REMAINS AT LEAST 4 FEET FROM THE EDGE OF THE STREET PAVEMENT, UNLESS OTHERWISE APPROVED BY THE CITY.
3. THE TOP OF THE CONCRETE SHALL BE AT AN ELEVATION NO LOWER THAN THE CROWN OF THE ADJACENT ROADWAY, AND NO HIGHER THAN 6 INCHES ABOVE THE CROWN UNLESS APPROVED BY THE CITY TO MAKE A MORE NATURAL TRANSITION WITH THE ADJACENT LAND.
4. ALL WALKS SHALL HAVE A CROSS SLOPE OF 1/4 INCH PER FOOT AND SHALL NOT EXCEED A LONGITUDINAL SLOPE OF 1:20, EXCEPT AT DESIGNATED RAMPS THAT SHALL NOT EXCEED 1:12. PROVIDE A TACTILE WARNING SURFACE AT ALL RAMPS PER A.D.A. THE CONTRACTOR SHALL INSURE THAT ALL PROVISIONS OF A.D.A AND FLORIDA ACCESSIBILITY CODE ARE MET.
5. ISOLATION JOINTS (TYPE A JOINTS) SHALL BE PROVIDED BETWEEN EXISTING SLABS OR STRUCTURES AND FRESH CONCRETE, TO SEPARATE PEDESTRIAN SECTIONS FROM SECTIONS WHICH WILL ENCOUNTER VEHICLE TRAFFIC, TO SEPARATE FRESH PLACEMENT FROM CONCRETE WHICH HAS SET FOR MORE THAN 60 MINUTES, AND NO FARTHER APART THAN 100 FEET IN SIDEWALKS AND BIKEPATHS. JOINT MATERIAL SHALL BE SPECIFIED IN FOOT STANDARDS AND SPECIFICATIONS AND SHALL BE RUBBER, PLASTIC OR OTHER APPROVED NON-BIODEGRADABLE ELASTOMERIC MATERIAL. WOOD IS PROHIBITED.
6. CONTROL JOINTS (TYPE B JOINTS) SHALL BE TOOLED INTO THE FRESH CONCRETE TO A DEPTH EQUAL TO 1/4 THE SLAB THICKNESS AND SPACED APART A DISTANCE EQUAL TO THE WIDTH OF THE SLAB OR 5 FEET WHICHEVER IS GREATEST.
7. THE SLAB SURFACE SHALL BE BROOM FINISHED TO BE SLIP RESISTANT, AND SHALL MATCH AS CLOSELY AS POSSIBLE THE FINISH OF THE EXISTING ADJACENT SLABS AND ALL EDGES SHALL BE TOOLED TO ELIMINATE SHARP CORNERS.
8. THE BEARING SUBSURFACE SHALL HAVE ALL ORGANIC, LOOSE, AND DELETERIOUS MATTER REMOVED, AND THE REMAINING CLEAN SOIL SHALL BE SMOOTH, SOUND, AND SOLID. ANY FILL MATERIAL SHALL BE COMPACTED WITH A VIBRATORY OR IMPACT COMPACTION MACHINE IN MAXIMUM 12 INCH LIFTS OR COMPACTED WITH A HAND TAMPER IN MAXIMUM 4 INCH LIFTS. THE CITY SHALL REQUIRE A COMPACTION TEST FOR EACH LIFT IF THE TOTAL FILLED SECTION IS MORE THAN 12 INCHES DEEP OR IF THE SUBSURFACE HAS BEEN DISTURBED MORE THAN 12 INCHES DEEP. WHERE SUCH TEST IS REQUIRED, THE RESULTS SHALL SHOW A MINIMUM PROCTOR FIELD DENSITY OF 95 PERCENT.
9. ALL CONCRETE WORK IN THE RIGHT-OF-WAY SHALL BE INSPECTED BY THE CITY AFTER THE SUBSOIL IS PREPARED AND THE FORMS ARE SET, BUT BEFORE THE CONCRETE PLACEMENT BEGINS.
10. THE CONTRACTOR SHALL BE RESPONSIBLE FOR PROTECTING THE FINISHED SLAB FROM ALL DAMAGE AND VANDALISM UNTIL THE CITY ACCEPTS OR APPROVES THE SLAB, AFTER WHICH TIME THE OWNER OF THE ABUTTING LAND SHALL BE RESPONSIBLE FOR THE SLAB IN ACCORDANCE WITH THE CITY CODE. ANY SLAB SECTION DAMAGED OR VANDALIZED PRIOR TO ACCEPTANCE OR APPROVAL SHALL BE CUT OUT BETWEEN JOINTS AND REPLACED. REPAIRS ARE NOT ACCEPTABLE.
11. SIDEWALKS LOCATED WITHIN THE RIGHT-OF-WAY SHALL NOT BE TINTED, STAINED, COLORED, OR COATED.
12. ALL FORMS SHALL BE REMOVED PRIOR TO ACCEPTANCE OR APPROVAL AND THE DISTURBED GROUND SHALL BE BACKFILLED, REGRADED, AND SODDED SO THAT THE WEAR SURFACE OF THE CONCRETE IS REASONABLY FLUSH WITH THE ADJACENT GRADE.



STANDARD CONSTRUCTION DETAIL  
SIDEWALK, RAMP, AND DRIVEWAY APRON  
CONSTRUCTION REQUIREMENTS

NTS

INDEX

M-3

March 2022

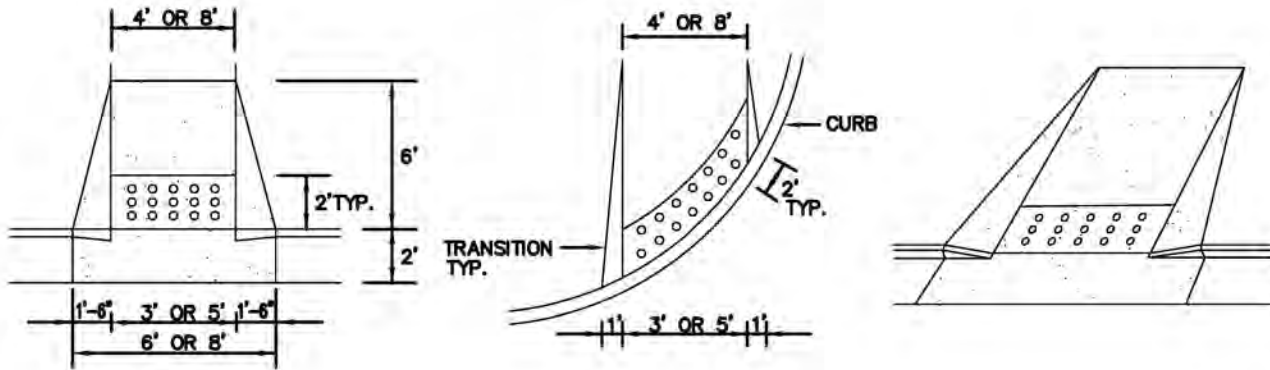

**NOTES:**

1. RAMP LOCATIONS ARE TO BE COORDINATED WITH AND IN CONFORMANCE WITH CROSSWALK MARKING DETAILS SHOWN IN THE PLANS.
2. CURBED RAMPS SHALL HAVE FLARED SIDES WITH A MAXIMUM SLOPE OF 12:1.
3. RAMPS SHALL HAVE A DETECTABLE WARNING SURFACE AS SHOWN.
4. RAMPS ARE TO BE CONSTRUCTED AT ALL LOCATIONS SHOWN IN THE PLANS EVEN WHEN A SIDEWALK IS NOT CONSTRUCTED CONCURRENTLY.
5. NO CURB TRANSITION IS NEEDED FOR MIAMI CURBS.
6. ALL RAMPS SHALL BE CONSTRUCTED IN ACCORDANCE WITH FDOT INDEX NO. 304 AND HANDICAPPED ACCESSIBILITY REQUIREMENTS IN ACCORDANCE WITH THE AMERICAN DISABILITIES ACT.

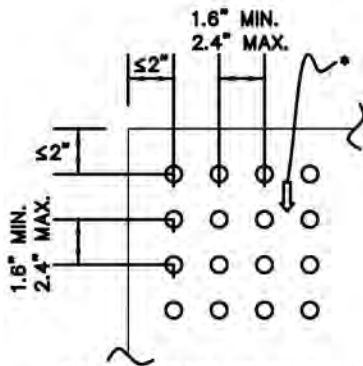

BASE-TO-BASE SPACING SHALL BE 0.65" MINIMUM BETWEEN DOMES.

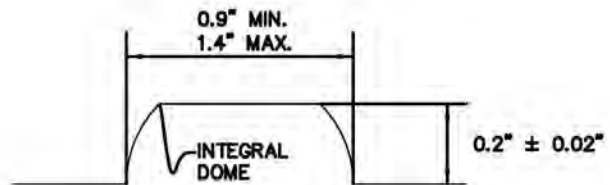

**NOTES:**

- \*\* ON RAMPS THAT ARE PERPENDICULAR WITH THE CURB LINE, THE DOME PATTERN SHALL BE IN-LINE WITH THE DIRECTION OF TRAVEL. ON RAMPS INTERSECTING CURBS ON A RADIUS, THE DOME PATTERN SHALL BE IN-LINE WITH THE DIRECTION OF TRAVEL TO THE EXTENT PRACTICAL.



STANDARD CONSTRUCTION DETAIL  
SIDEWALK AND BIKE PATH RAMP  
NTS

INDEX

M-4

March 2022

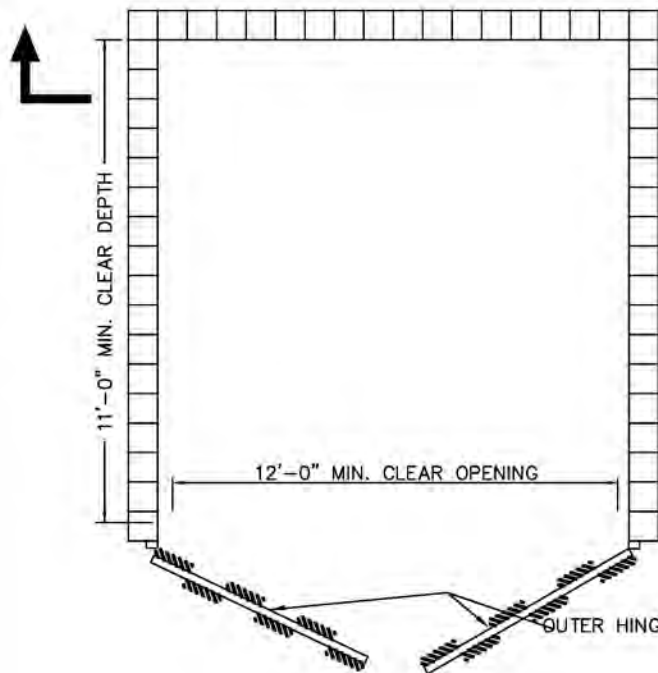

PLAN VIEW

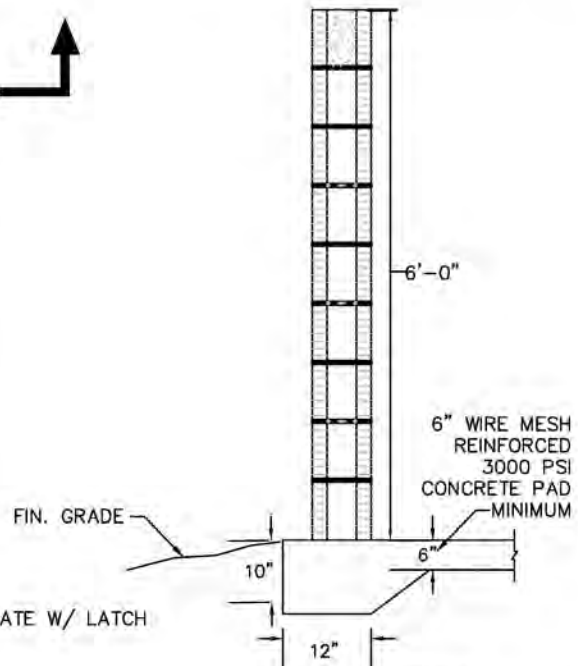

WALL SECTION

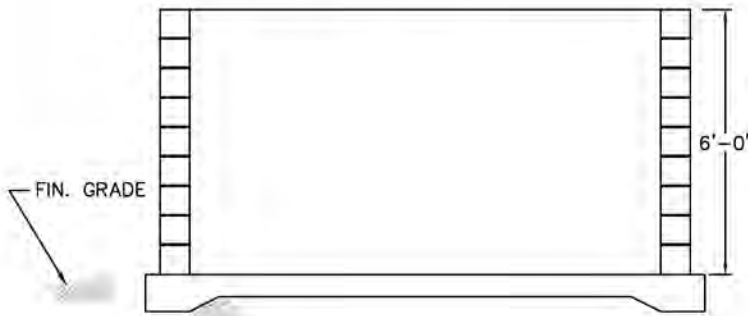

SECTION

NOTE TO DESIGNER:

1. THIS DETAIL REFLECTS CITY DIMENSIONAL REQUIREMENTS FOR THE DUMPSTER ENCLOSURE ONLY.
2. PROVIDE PROPOSED WALL MATERIAL AND HORIZONTAL AND VERTICAL WALL REINFORCING REQUIREMENTS.
3. PROVIDE PROPOSED SLAB DESIGN REQUIREMENTS INCLUDING REINFORCING.
4. PROVIDE ANY OTHER CONSTRUCTION DETAILS THAT MAY BE REQUIRED.

NOTES:

- 1) BLOCK MUST BE FINISHED WITH STUCCO AND PAINTED
- 2) DUMPSTER STRUCTURE SHALL MEET THE REQUIREMENTS OF THE LAND DEVELOPEMENT CODE (LDC).
- 3) SHRUB PLANTINGS REQUIRED (MIN. 3-FOOT WIDE PLANTING AREA) AROUND PERIMETER WALLS (EXCEPT OPENING).
- 4) GATES TO BE CONSTRUCTED OF PRESSURE-TREATED WOOD, OR APPROVED EQUAL.
- 5) DUMPSTER ENCLOSURE HEIGHT MAY BE INCREASED TO A MAXIMUM HEIGHT OF EIGHT (8) FEET.

NB- The City of Bunnell Solid Waste Director may grant exceptions if compliance is deemed to be impossible or impractical



STANDARD CONSTRUCTION DETAIL  
SINGLE USE DUMPSTER ENCLOSURE  
NTS

INDEX

M-5

March 2022



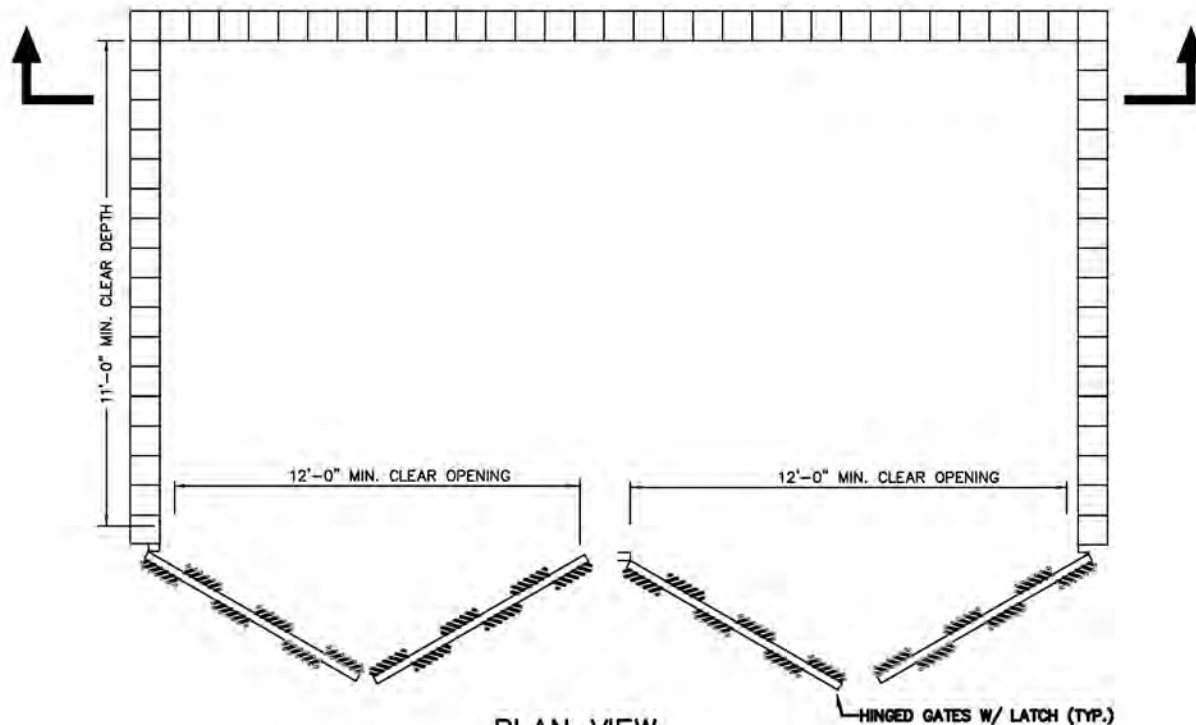

**PLAN VIEW**

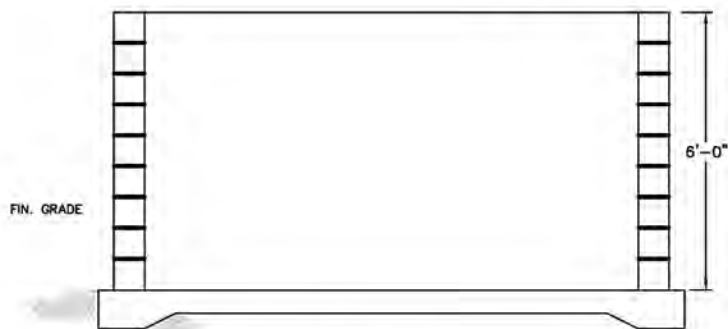

**SECTION**

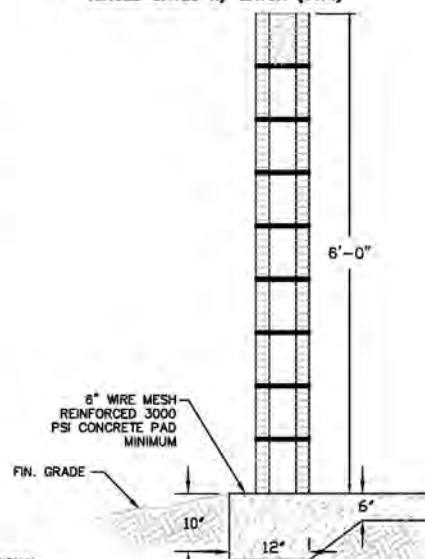

**WALL SECTION**

**NOTES:**

- 1) BLOCK MUST BE FINISHED WITH STUCCO AND PAINTED TO MATCH BUILDING.
- 2) DUMPSTER STRUCTURE SHALL MEET THE REQUIREMENTS OF THE LAND DEVELOPMENT CODE (LDC).
- 3) SHRUB PLANTINGS REQUIRED (MIN. 3-FOOT WIDE PLANTING AREA) AROUND PERIMETER WALLS (EXCEPT OPENING).
- 4) GATES TO BE CONSTRUCTED OF PRESSURE-TREATED WOOD, OR APPROVED EQUAL.
- 5) DUMPSTER ENCLOSURE HEIGHT MAY BE INCREASED TO A MAXIMUM HEIGHT OF (8) FEET

**NOTE TO DESIGNER:**

1. THIS DETAIL REFLECTS CITY DIMENSIONAL REQUIREMENTS FOR THE DUMPSTER ENCLOSURE ONLY.
2. PROVIDE PROPOSED WALL MATERIAL AND HORIZONTAL AND VERTICAL WALL REINFORCING REQUIREMENTS.
3. PROVIDE PROPOSED SLAB DESIGN REQUIREMENTS INCLUDING REINFORCING.
4. PROVIDE ANY OTHER CONSTRUCTION DETAILS THAT MAY BE REQUIRED.



**STANDARD CONSTRUCTION DETAIL  
DUAL-USE DUMPSTER ENCLOSURE  
NTS.**

**INDEX**

**M-6**

**March 2022**

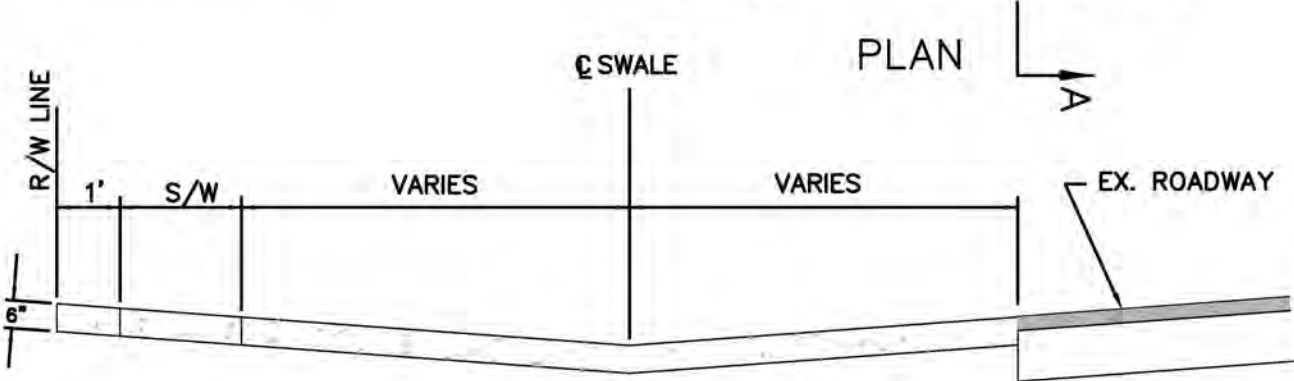
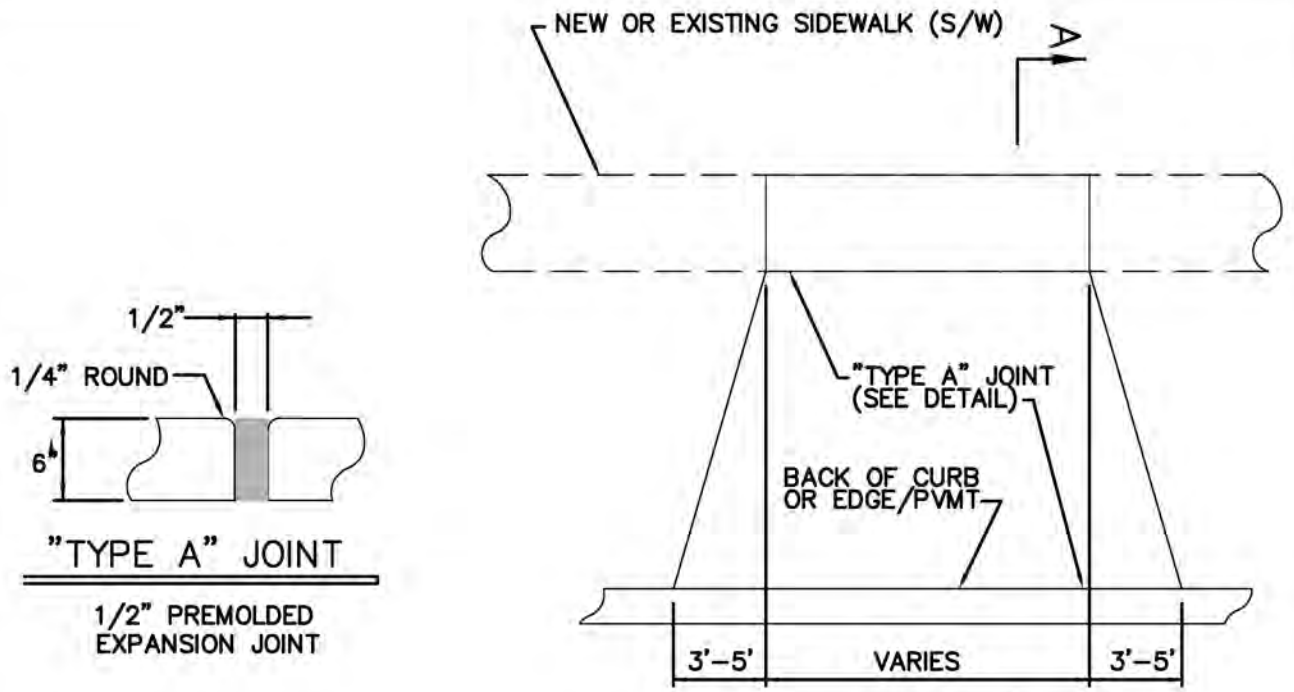

RURAL SECTION "A-A"

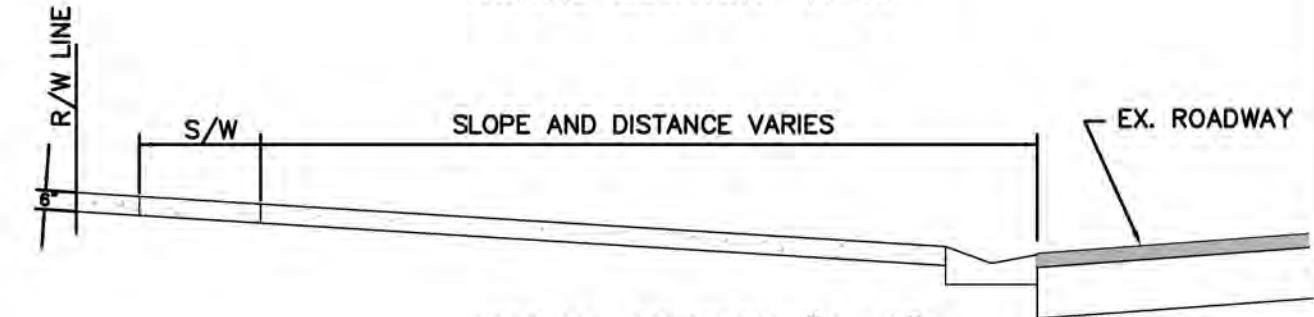

URBAN SECTION "A-A"

DRIVEWAY APRON BASE TO BE COMPACTED AND TESTED TO 95% DENSITY WITH MINIMUM L.B.R. 40 BASED ON AASHTO MODIFIED PROCTOR TEST F.B.V.-75  
 CONCRETE DRIVEWAY APRON TO BE 28 DAY, 3000 PSI.



STANDARD CONSTRUCTION DETAIL  
 RESIDENTIAL DRIVEWAY APRON  
 DRAWINGS  
 NTS

INDEX

M-7

March 2022

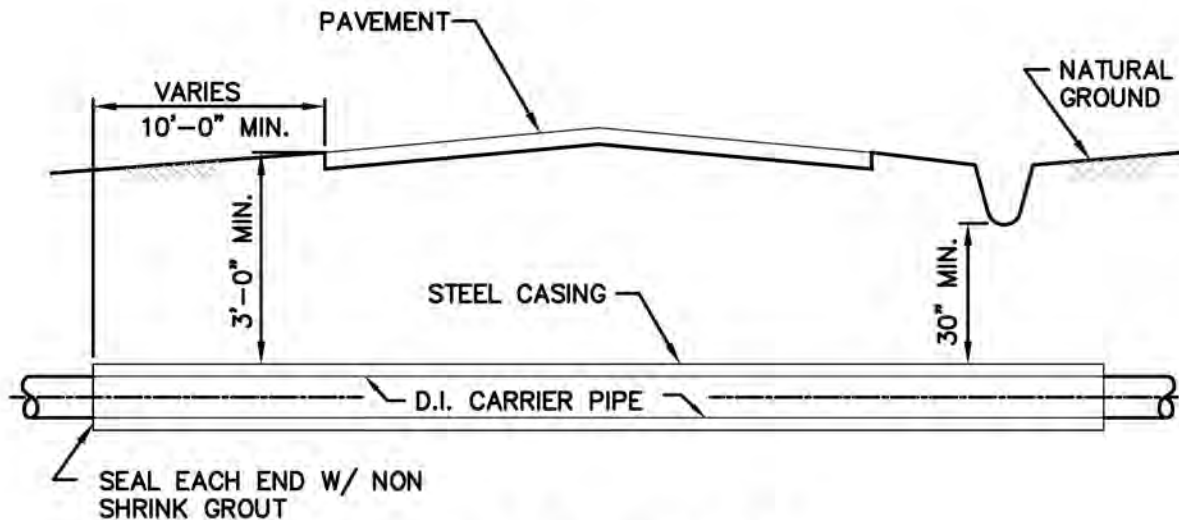

NOTE: BORING & JACKING TO BE IN ACCORDANCE W/ FLA. D.O.T. SPECs.

**NOTES**

1. MINIMUM COVER FOR TOP OF CASING ON ALL CITY STREETS SHALL BE 3.0'
2. ROTATION OF CARRIER PIPE INSIDE THE CASING PIPE WILL NOT BE PERMITTED. RESTRAINED MECHANICAL OR FLANGED JOINT PIPE SHALL BE USED TO HELP PREVENT SUCH ROTATION.
3. THE CONTRACTOR SHALL SUBMIT SHOP DRAWINGS OF CASING AND CARRIER PIPE INSTALLATION FOR APPROVAL PRIOR TO FABRICATION OF PIPING, CASING, AND APPURTENANCES. CERTIFICATION OF CASING PIPE IS REQUIRED.
4. GROUTING OF SPACE BETWEEN CASING AND CARRIER PIPE NOT REQUIRED UNLESS NEGATIVE FLOTATION EXISTS.
5. WELDING OF CASING PIPE TO BE DONE BY CERTIFIED WELDER. ALL ENDS OF CASING PIPE SHALL BE CHAMFERED PRIOR TO ANY WELDING.
6. SEAL END OF CASING PIPE WITH NON-SHRINK GROUT.
7. CITY INSPECTOR SHALL BE PRESENT THROUGHOUT ALL BORE AND JACK ACTIVITIES.

**NOTE TO ENGINEER**

CROSSING DETAIL SHALL BE TO SIZE AND SCALE. SHOW ALL EXISTING UTILITIES, CLEARANCES, CARRIER AND CASING SIZE AND LENGTH, LOCATION OF PAVED ROAD, LIMITS OF RIGHT OF WAY, EXISTING AND PROPOSED SPOT ELEVATIONS AND PROPOSED PIPE INVERT ELEVATIONS.



STANDARD CONSTRUCTION DETAIL

BORE AND JACK  
NTS

INDEX

M-8

March 2022

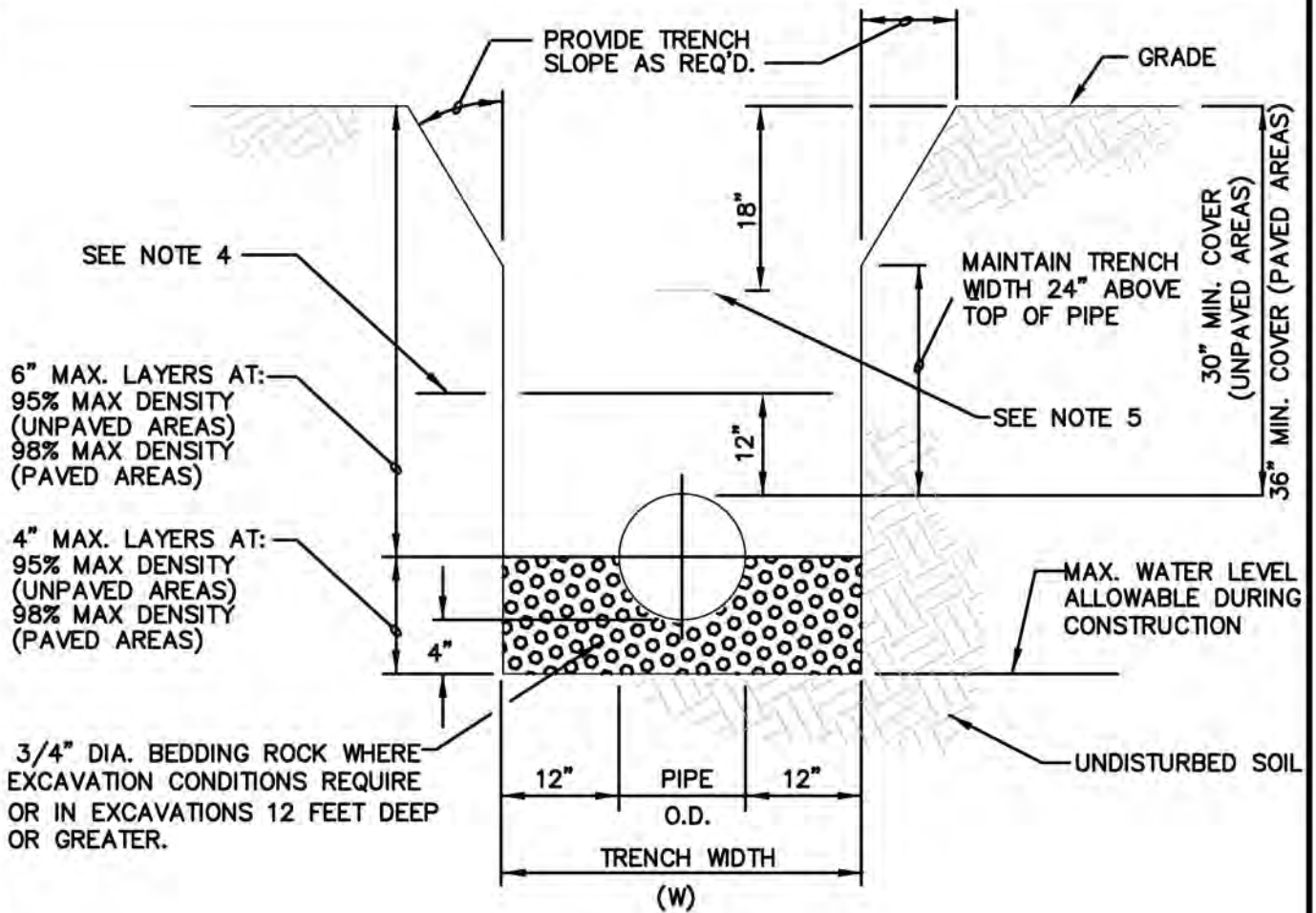

## PIPE INSTALLATION DETAIL

### NOTES:

1. WHERE SOIL CONDITIONS CAN NOT BE MAINTAINED AS SHOWN ABOVE, PROVIDE APPROVED METHOD OF CONSTRUCTION.
2. SHEETING WILL BE REQUIRED AS DETERMINED IN THE FIELD.
3. COMPACTION PERCENTAGES SHOWN REFER TO A.A.S.H.T.O. T-180. PROVIDE COPIES OF CERTIFIED TEST REPORTS TO CITY INSPECTOR.
4. MECHANICAL COMPACTION NOT ALLOWED BELOW THIS LEVEL.
5. INSTALL METALLIC TAPE OVER FULL LENGTH OF PIPE.



STANDARD CONSTRUCTION DETAIL  
PIPE INSTALLATION  
NTS

INDEX

M-9

March 2022

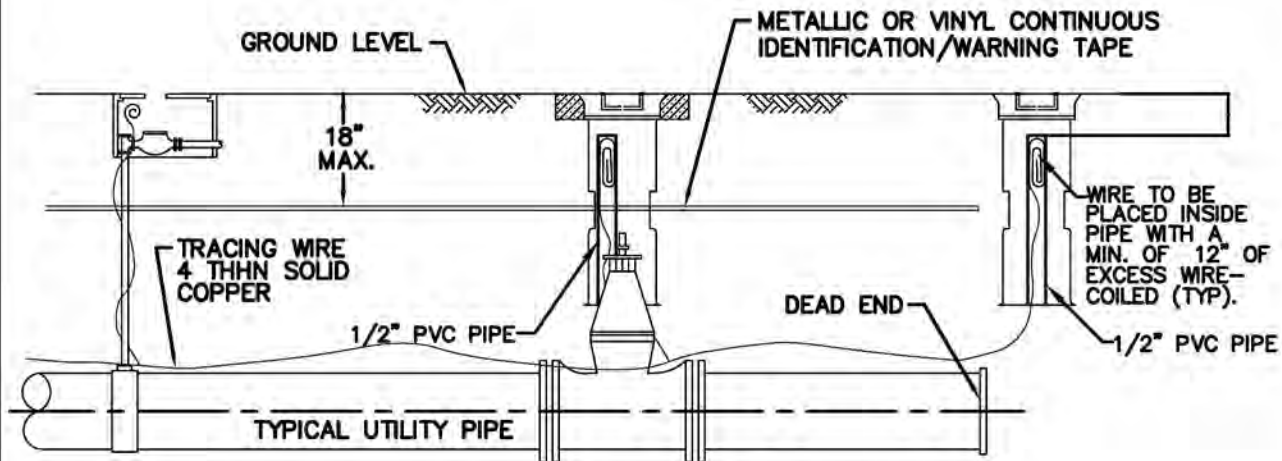

ALL PVC PIPE, OR OTHER CITY APPROVED NONMETALLIC PIPE INSTALLED WITHIN THE CITY'S WATER, SANITARY SEWER, OR RECLAIMED WATER SYSTEMS, SHALL BE INSTALLED WITH 4 THHN SOLID COPPER TRACING WIRE. IF PIPE IS INSTALLED BY DIRECTIONAL BORE, USE (2) 10 THHN SOLID COPPER TRACING WIRE.

THE TRACING WIRE MUST BE INSTALLED DIRECTLY ABOVE THE PIPE, TAPED AT 10 & 2 O'CLOCK ON THE PIPE, AND BROUGHT TO THE SURFACE AT 500' MINIMUM INTERVALS. WIRE SHALL EXTEND A MINIMUM OF 12" ABOVE GRADE AT EACH INTERVAL AND BE COILED AND PLACED IN A VALVE BOX, METER BOX, MANHOLE, CLEANOUT OR OTHER APPLICABLE STRUCTURE. NO END OF WIRE ROLL SPLICES WILL BE PERMITTED AT THE END OF A ROLL. THE TRACING WIRE MUST BE BROUGHT TO THE SURFACE AND TERMINATED IN A VALVE BOX.

TRACING WIRE BETWEEN INTERVALS SHALL BE INSTALLED SO AS TO PROVIDE CONTINUOUS CURRENT WHEN LINE LOCATION EQUIPMENT IS CONNECTED TO THE TRACING WIRE. WIRE BRANCHING FROM MAIN LINES SHALL BE LINKED BY A CITY APPROVED CONNECTOR SUCH AS KING # 2011 SAFETY SEALED CONNECTORS OR APPROVED EQUAL.

**COLOR CODING:**

POTABLE WATER SYSTEM:	BLUE
RECLAIMED WATER SYSTEM:	LAVENDER
SANITARY SEWER FORCE MAIN SYSTEM:	GREEN

1. POTABLE WATER AND RECLAIMED WATER SYSTEMS: WIRE SHALL BE INSTALLED ABOVE ALL MAINS AND SERVICE LINES, TAPED AT 10 & 2 O'CLOCK AND ATTACHED TO VALVES, HYDRANTS AND FITTINGS. WIRE INSTALLED WITH SERVICE LINES SHALL CONNECT TO THE WIRE INSTALLED ABOVE THE MAIN AND EXTEND TO THE CURB STOP.
2. FIRE SPRINKLER LINES: WIRE SHALL CONNECT TO THE WIRE INSTALLED ABOVE THE MAIN, TAPED AT 10 & 2 O'CLOCK AND EXTEND TO THE RISER CONNECTION.
3. SANITARY SEWER FORCE MAINS: WIRE SHALL BE INSTALLED ABOVE THE FORCE MAIN, TAPED AT 10 & 2 O'CLOCK ON THE PIPE, ATTACHED TO ALL VALVES & FITTINGS AND BROUGHT TO THE SURFACE AND PLACED IN A METAL, CITY APPROVED, VALVE BOX.
4. DEAD END MAINS: WIRE SHALL BE PLACED IN A PROPERLY IDENTIFIED METAL VALVE BOX AT THE END OF THE RUN.
5. WIRE SHALL NOT BE FASTENED OR COILED TO VALVE OPERATING NUT.
6. CONTINUITY TESTING OF THE TRACING WIRE WITH A CERTIFICATION STATEMENT BY THE TESTING AGENCY MUST OCCUR PRIOR TO ACCEPTANCE OF ANY PIPE BY THE CITY.



**STANDARD CONSTRUCTION DETAIL**  
**UTILITY PIPE LOCATION MATERIALS**  
 NTS

INDEX

M-10

March 2022

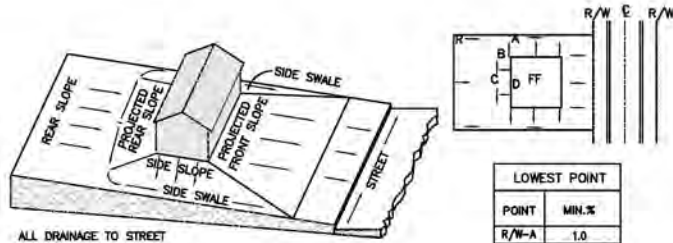

ALL DRAINAGE TO STREET  
 (A) DENOTES LOT GRADING TYPE

LOWEST POINT	
POINT	MIN. %
R/W-A	1.0
B-A	5.0
C-B	1.0
D-C	2.0
D-FF	MIN. 0.67
R-A	1.0

**LOT GRADING PLAN "A"**  
 N.T.S.

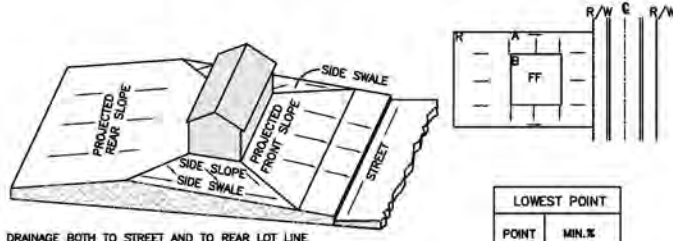

DRAINAGE BOTH TO STREET AND TO REAR LOT LINE  
 (B) DENOTES LOT GRADING TYPE

LOWEST POINT	
POINT	MIN. %
R/W-A	1.0
B-A	5.0
B-FF	MIN. 0.7
A-R	1.0

**LOT GRADING PLAN "B"**  
 N.T.S.

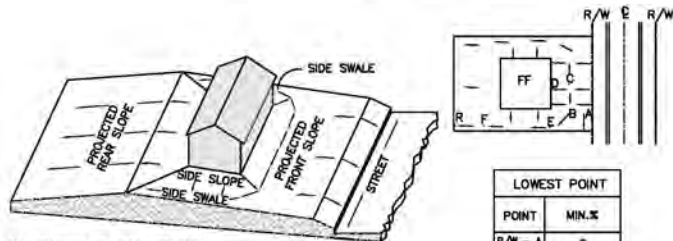

ALL DRAINAGE TO REAR LOT LINE  
 (C) DENOTES LOT GRADING TYPE

LOWEST POINT	
POINT	MIN. %
R/W - A	0
A - B	MAX. 13.5
B - C	1.0
C - D	5.0'
D - FF	0.67'
B - E	1.0
E - F	1.0
F - R	1.0

**LOT GRADING PLAN "C"**  
 N.T.S.

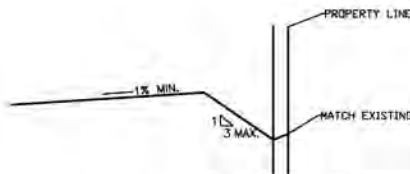

**LOT GRADING PLANS**  
 N.T.S.



STANDARD CONSTRUCTION DETAIL  
 LOT GRADING PLAN  
 NTS

INDEX  
 M-11  
 March 2022

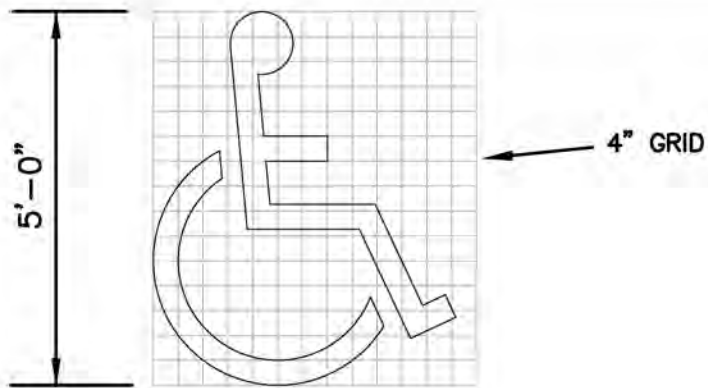

**HANDICAPPED  
PAVEMENT SYMBOL**

USE OF PAVEMENT SYMBOL IN HANDICAPPED PARKING SPACES IS REQUIRED. THE SYMBOL SHALL BE 5 FT. HIGH AND WHITE TO BE INSTALLED IN ACCORDANCE WITH FDOT STANDARD PLANS INDEX #711-001 (SHEET 11)

BLUE STRIP IS TO BE TINTED TO MATCH SHADE 15180 OF FEDERAL STANDARDS 595A

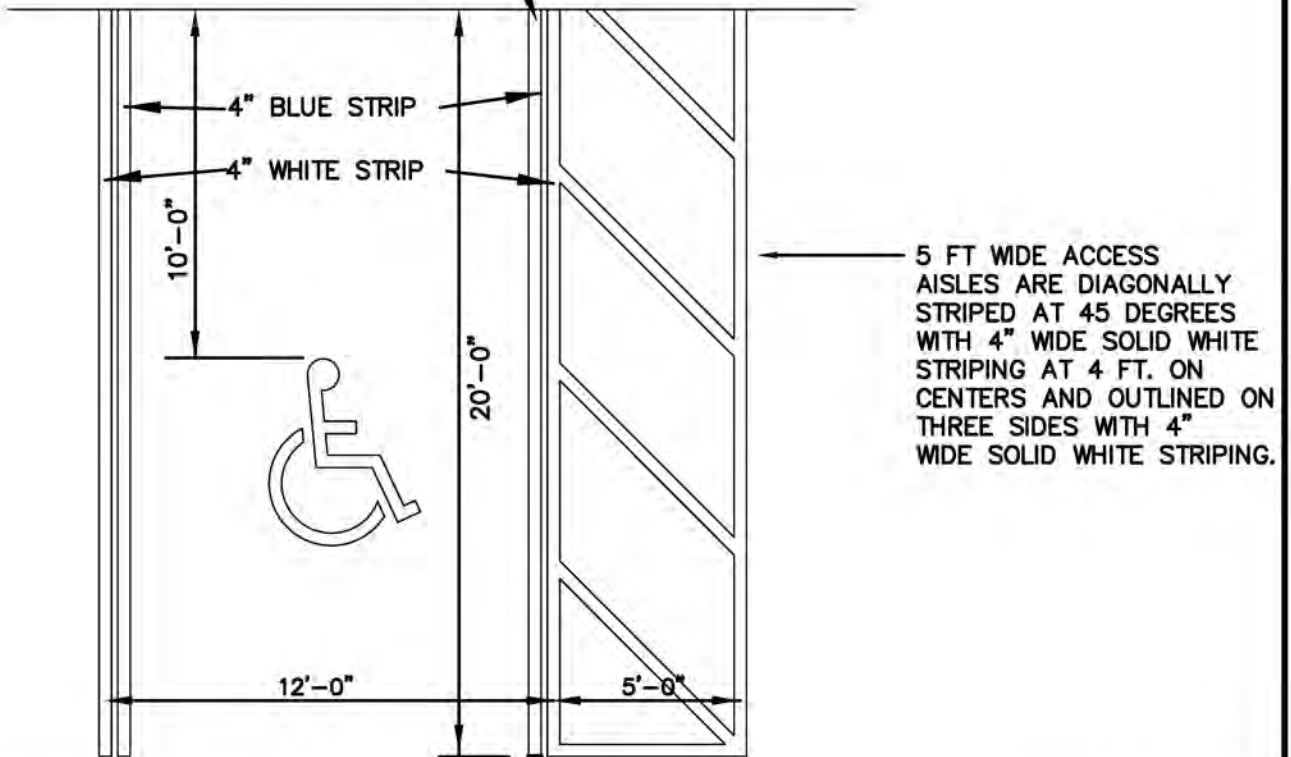

STANDARD CONSTRUCTION DETAIL  
TYPICAL MARKINGS FOR HANDICAPPED PARKING  
NTS

INDEX

M-12A

March 2022

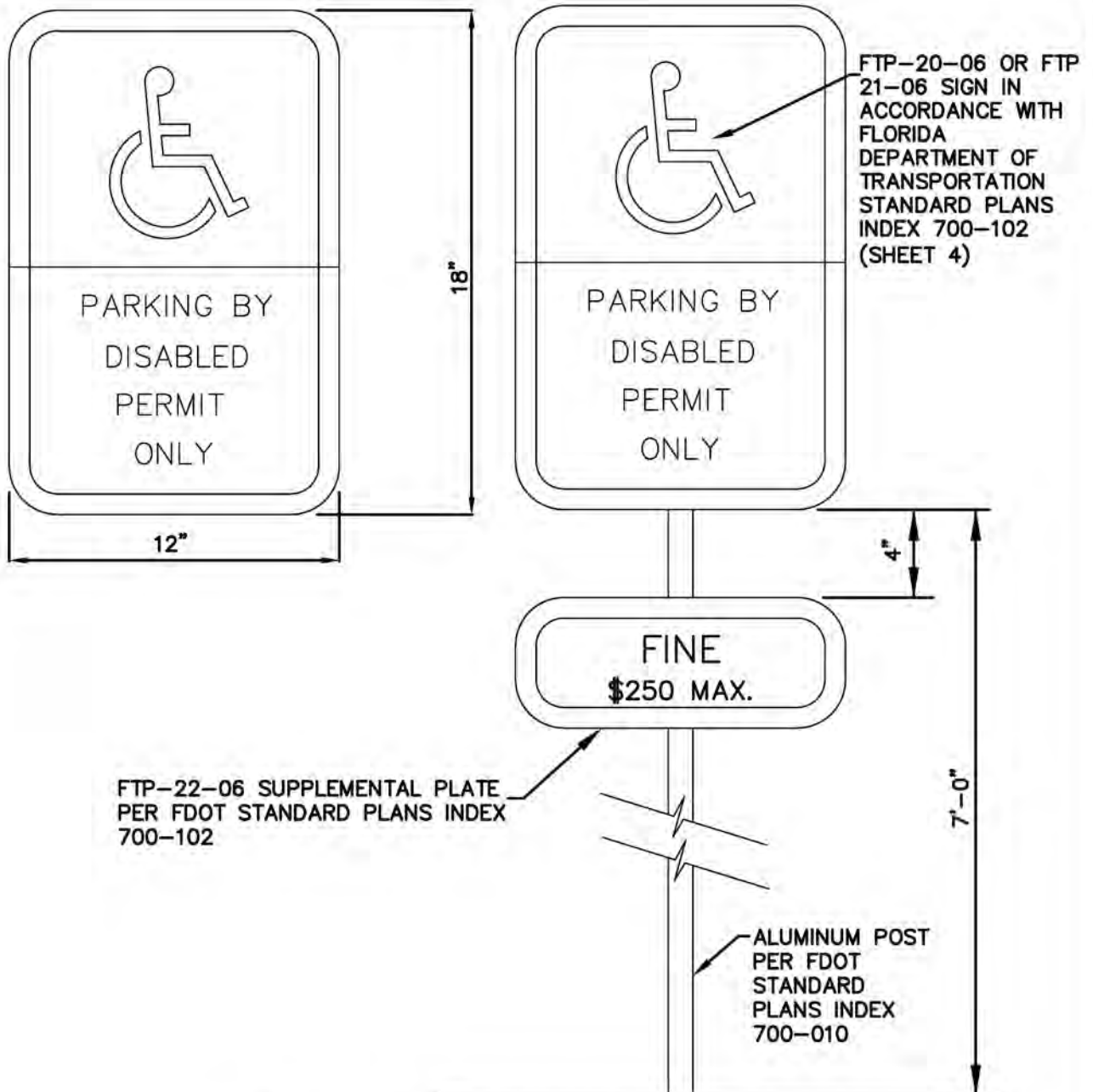

- 1.) TOP PORTION OF SIGN TO HAVE A REFLECTIVE BLUE BACKGROUND WITH WHITE REFLECTIVE SYMBOL AND BORDER.
- 2.) BOTTOM PORTION SHALL HAVE A REFLECTIVE WHITE BACKGROUND WITH BLACK OPAQUE LEGEND AND BORDER.
- 3.) SIGN MAY BE FABRICATED ON ONE PANEL OR TWO.
- 4.) SIGNS ARE TO BE MOUNTED AT STANDARD HEIGHT. (7' FROM PAVEMENT TO BOTTOM OF SIGN) AND WITHSTAND 150 MPH WIND.



STANDARD CONSTRUCTION DETAIL  
HANDICAP PARKING SIGN DETAIL  
NTS

INDEX

M-12B

March 2022



**ES BMP 1.01**

**TEMPORARY GRAVEL CONSTRUCTION ENTRANCE**

**DEFINITION**

A STONE STABILIZED PAD LOCATED AT POINTS OF VEHICULAR INGRESS AND EGRESS ON A CONSTRUCTION SITE.

**PURPOSE**

TO REDUCE THE AMOUNT OF SEDIMENT TRANSPORTED ONTO PUBLIC ROADS BY MOTOR VEHICLES OR RUNOFF.

**CONDITIONS WHERE PRACTICE APPLIES**

WHEREVER TRAFFIC WILL BE LEAVING A CONSTRUCTION SITE AND MOVES DIRECTLY ONTO A PUBLIC ROAD OR OTHER PAVED AREA.

**PLANNING CONSIDERATIONS**

CONSTRUCTION ENTRANCES PROVIDE AN AREA WHERE MUD CAN BE REMOVED FROM CONSTRUCTION VEHICLE TIRES BEFORE THE ENTER A PUBLIC ROAD. IF THE ACTION OF THE VEHICLE TRAVELING OVER THE GRAVEL PAD IS NOT SUFFICIENT TO REMOVE THE MAJORITY OF THE MUD, THEN THE TIRES MUST BE WASHED BEFORE THE VEHICLE ENTERS A PUBLIC ROAD. IF WASHING IS USED, PROVISIONS MUST BE MADE TO INTERCEPT THE WASH WATER AND TRAP THE SEDIMENT BEFORE IT IS CARRIED OFF-SITE. CONSTRUCTION ENTRANCES SHOULD BE USED IN CONJUNCTION WITH THE STABILIZATION OF CONSTRUCTION ROADS TO REDUCE THE AMOUNT OF MUD PICKED UP BY CONSTRUCTION VEHICLES.

**DESIGN CRITERIA**

**AGGREGATE SIZE**

FDOT AGGREGATE NO. 1 (1.5 - 3.5 INCH STONE) SHOULD BE USED.

**ENTRANCE DIMENSIONS**

AGGREGATE LAYER MUST BE AT LEAST 6 INCHES THICK. IT MUST EXTEND THE FULL WIDTH OF THE VEHICULAR INGRESS AND EGRESS AREA. THE LENGTH OF THE ENTRANCE MUST BE AT LEAST 50 FEET. (SEE DETAIL).

**WASHING**

IF CONDITIONS OF THE SITE ARE SUCH THAT THE MAJORITY OF THE MUD IS NOT REMOVED BY THE VEHICLES TRAVELING OVER THE GRAVEL, THEN THE TIRES OF THE VEHICLES MUST BE WASHED BEFORE ENTERING A PUBLIC ROAD. WASH WATER MUST BE CARRIED AWAY FROM THE ENTRANCE TO A SETTLING AREA TO REMOVE SEDIMENT. A WASH RACK MAY ALSO BE USED TO MAKE WASHING MORE CONVENIENT AND EFFECTIVE. SEE DETAIL.

**LOCATION**

THE ENTRANCE SHOULD BE LOCATED TO PROVIDE FOR MAXIMUM UTILITY BY ALL CONSTRUCTION VEHICLES.

INDICATE PROPOSED LOCATION OF GRAVEL CONSTRUCTION ENTRANCE ON THE GRADING PLAN.

**CONSTRUCTION SPECIFICATIONS**

THE AREA OF THE ENTRANCE SHOULD BE CLEARED OF ALL VEGETATION, ROOTS AND OTHER OBJECTIONABLE MATERIAL. THE GRAVEL SHALL BE PLACED TO THE SPECIFIED DIMENSIONS. ANY DRAINAGE FACILITIES REQUIRED BECAUSE OF WASHING SHOULD BE CONSTRUCTED ACCORDING TO SPECIFICATIONS. IF WASH RACKS ARE USED, THEY SHOULD BE CONSTRUCTED ACCORDING TO SPECIFICATIONS.

**MAINTENANCE**

THE ENTRANCE SHALL BE MAINTAINED IN A CONDITION WHICH WILL PREVENT TRACKING OF FLOW OF MUD ONTO PUBLIC RIGHTS-OF-WAY. THIS MAY REQUIRE PERIODIC TOP DRESSING WITH 2-INCH STONE, AS CONDITIONS DEMAND AND REPAIR AND/OR CLEANOUT OF ANY STRUCTURES USED TO TRAP SEDIMENT. ALL MATERIALS SPILLED, DROPPED, WASHED OR TRACKED FROM VEHICLES ONTO ROADWAYS OR INTO STORM DRAINS MUST BE REMOVED IMMEDIATELY.

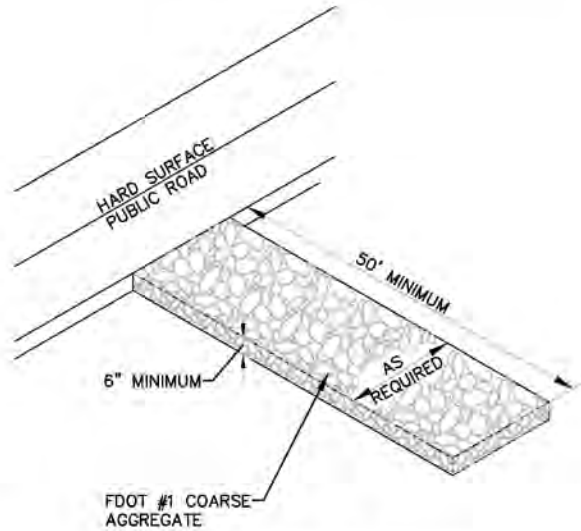

**GRAVEL CONSTRUCTION ENTRANCE**  
N.T.S.

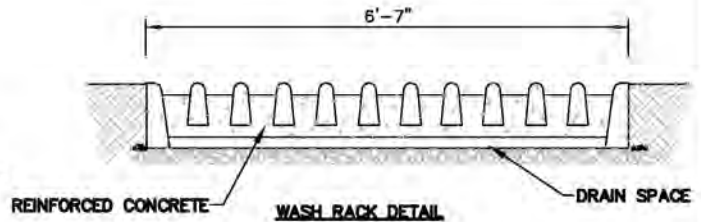
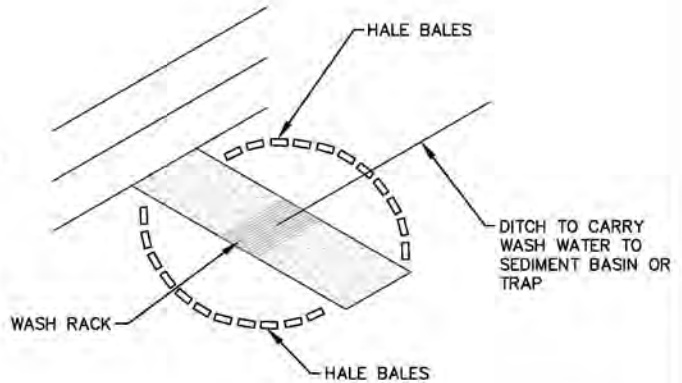

**GRAVEL CONSTRUCTION ENTRANCE**  
W/ WASH RACK (IF REQUIRED)

**NOTE:** COMPLY WITH FDOT REQUIREMENTS FOR SOIL TRACKING PREVENTION DEVICE IN FDOT ROADWAY ROW (STANDARD SPECIFICATION SECTION 104)



**STANDARD CONSTRUCTION DETAIL**  
**TEMPORARY GRAVEL CONSTRUCTION ENTRANCE**  
NTS

INDEX
M-13
March 2022

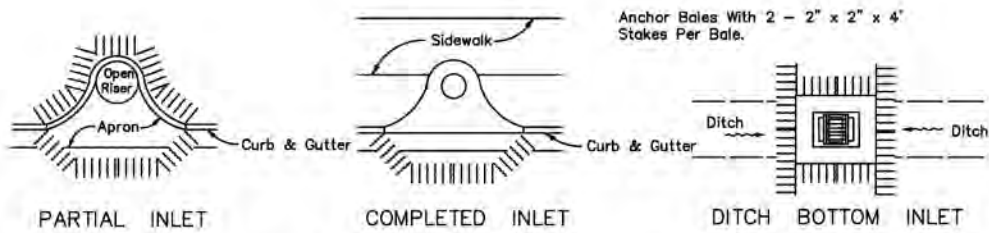

**PROTECTION AROUND INLETS OR SIMILAR STRUCTURES**

NOTE: SUBSTITUTE ROCK BAGS AT PAVED SURFACES

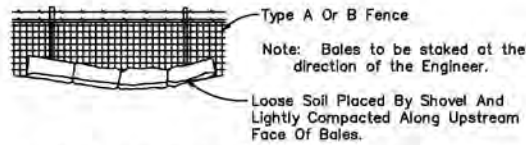

**BALES BACKED BY FENCE**

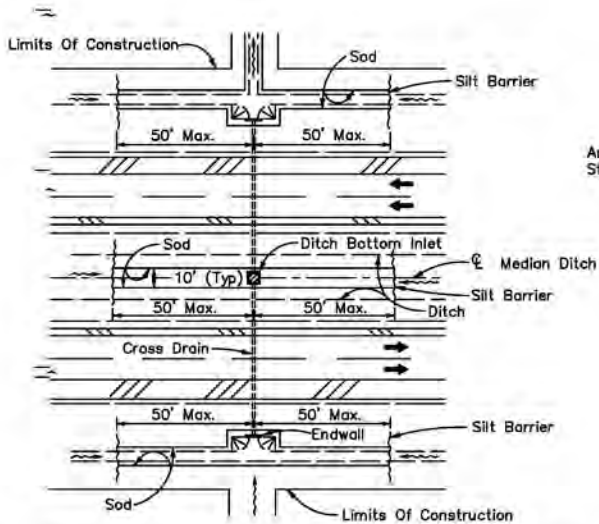

**DITCH INSTALLATIONS AT DRAINAGE STRUCTURES**

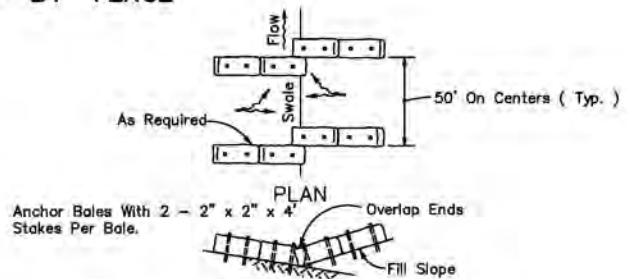

**ELEVATION**

TO BE USED AT SELECTED SITES WHERE THE NATURAL GROUND SLOPES TOWARD THE TOE OF SLOPE

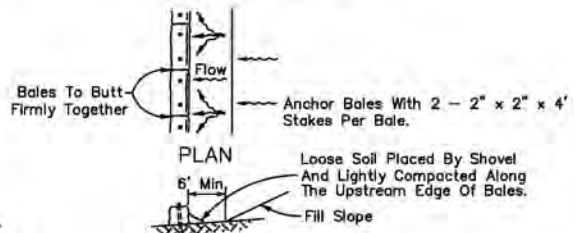

**ELEVATION**

TO BE USED AT SELECTED SITES WHERE THE NATURAL GROUND SLOPES AWAY FROM THE TOE OF SLOPE

**BARRIERS FOR FILL SLOPES**



**STANDARD CONSTRUCTION DETAIL  
EROSION CONTROL - SYNTHETIC BALES**

NTS

INDEX

M-14

March 2022

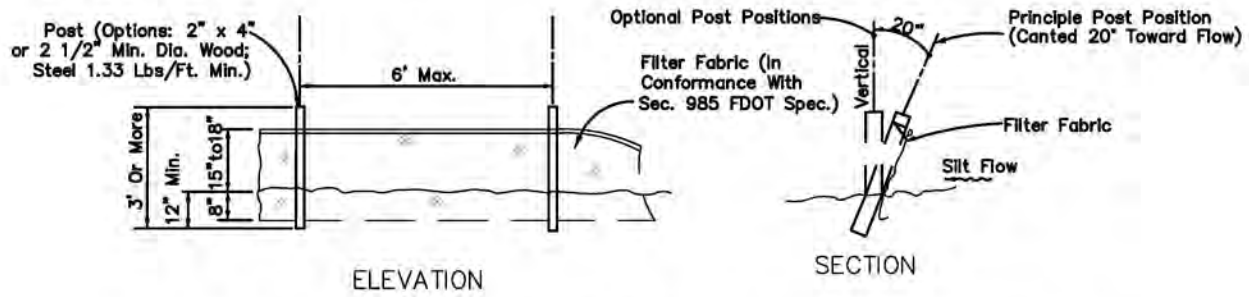

Note: Silt Fence to be paid for under the contract unit price for Staked Silt Fence (LF).

### TYPE III SILT FENCE



Note: Spacing for Type III Fence to be in accordance with FDOT Design Index No. 102, Chart I, Sheet 1 of 3 and ditch installations at drainage structures Sheet 2 of 3.

Type III Silt Fence

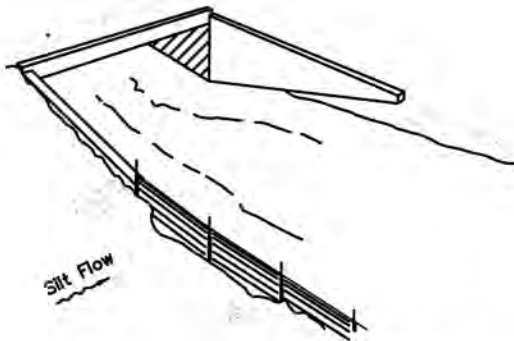

Type III Silt Fence

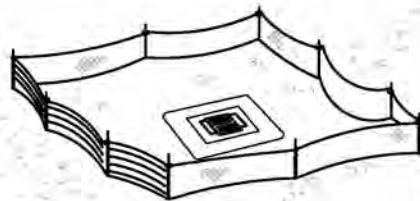

Type III Silt Fence Protection Around Ditch Bottom Inlets.

Do not deploy in a manner that silt fences will act as a dam across permanent flowing watercourses. Silt fences are to be used at upland locations and turbidity barriers used at permanent bodies of water.

### SILT FENCE APPLICATIONS



## STANDARD CONSTRUCTION DETAIL

### EROSION CONTROL – SILT FENCE

NTS

INDEX

M-15

March 2022

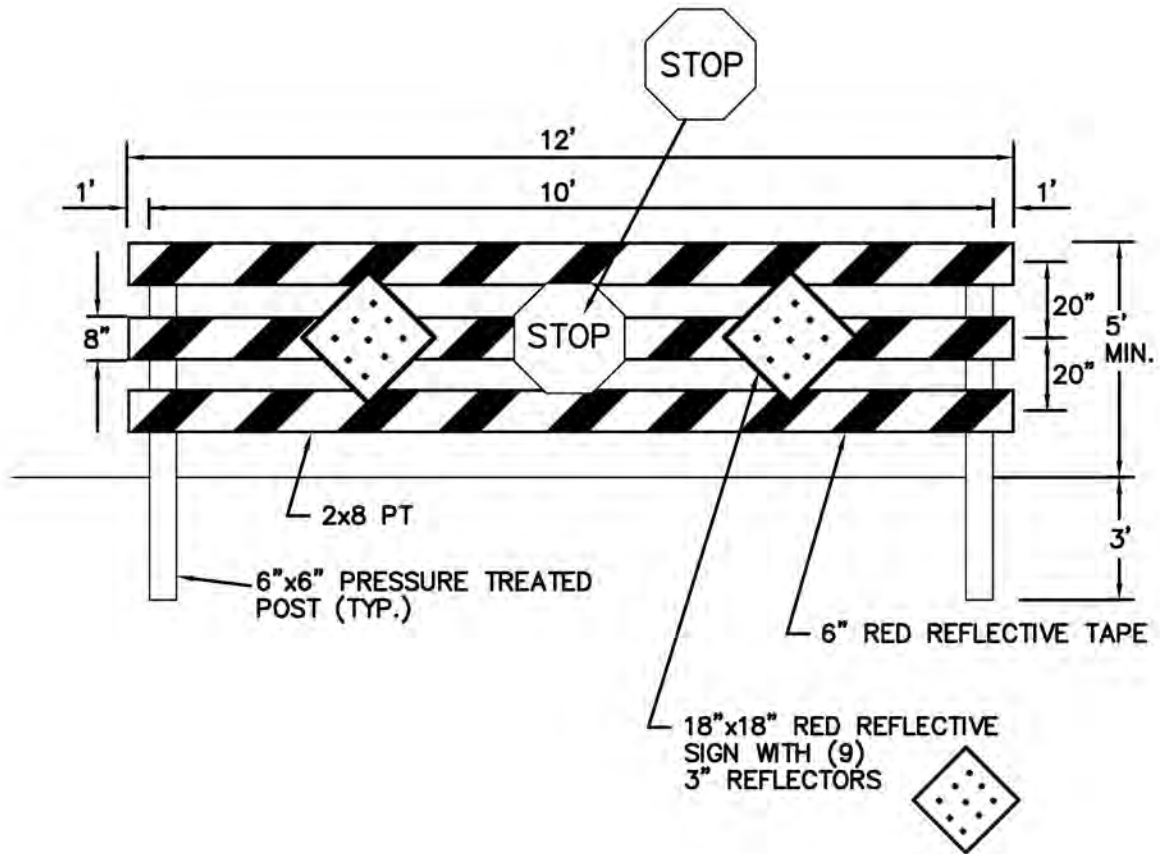

STANDARD CONSTRUCTION DETAIL  
ROAD BARRICADE  
NTS

INDEX

M-16

March 2022

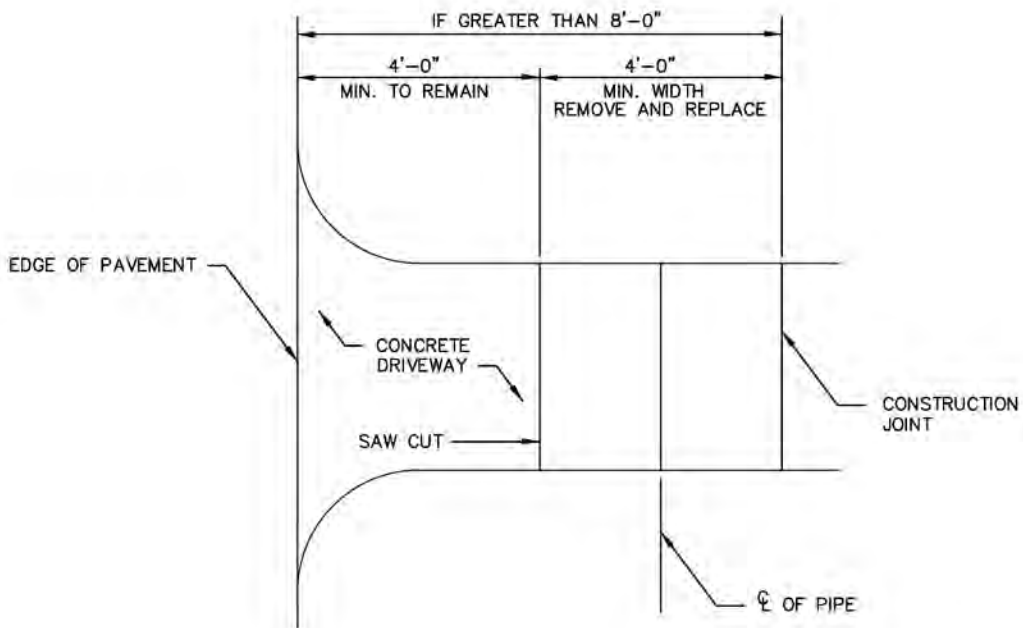
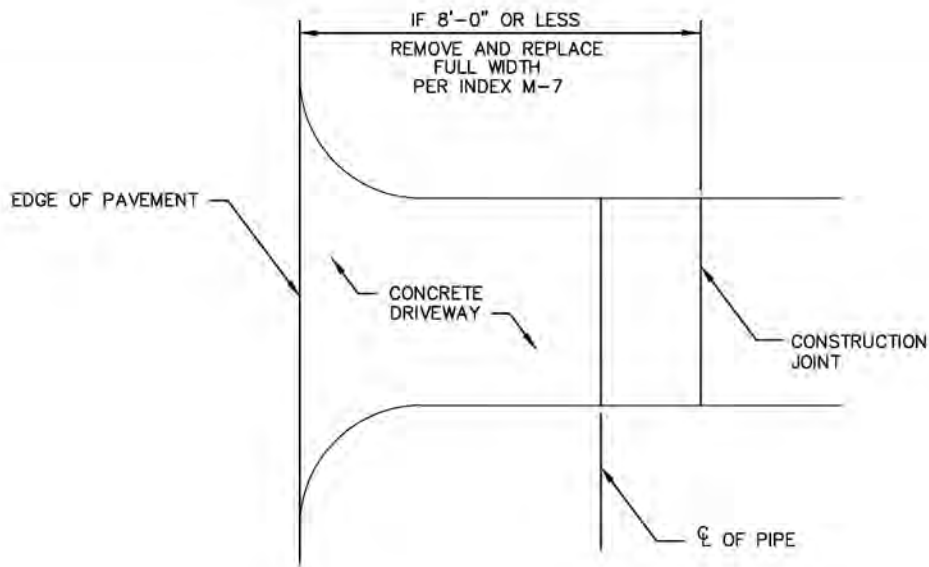

- 1) CONCRETE SHALL BE PLACED MINIMUM SIX (6) INCHES THICK AND BE 3000 PSI, 28 DAY STRENGTH.
- 2) SUBGRADE SHALL BE UNIFORM NON-ORGANIC SOIL OR BASE MATERIAL FREE OF DEBRIS AND COMPACTED TO 95% DENSITY, MINIMUM LBR40, AASHTO FBV-75



STANDARD CONSTRUCTION DETAIL  
DRIVEWAY CUT REPAIR AT UTILITY CROSSING  
NTS.

INDEX

M-17

March 2022



**STANDARD CONSTRUCTION DETAIL**  
**6' HIGH CHAIN LINK FENCE DETAIL**  
 NTS.

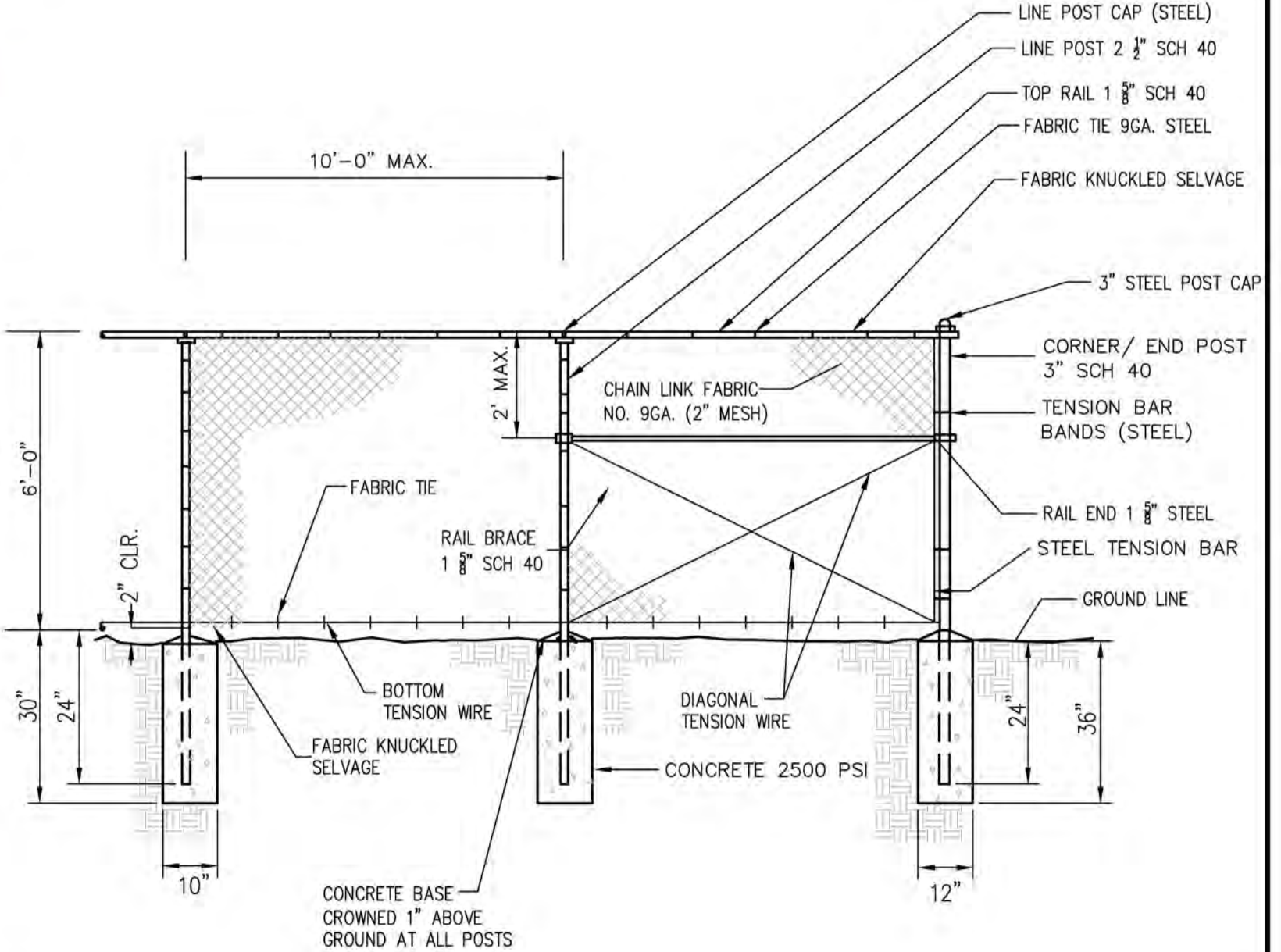

INDEX

M-18

March 2022

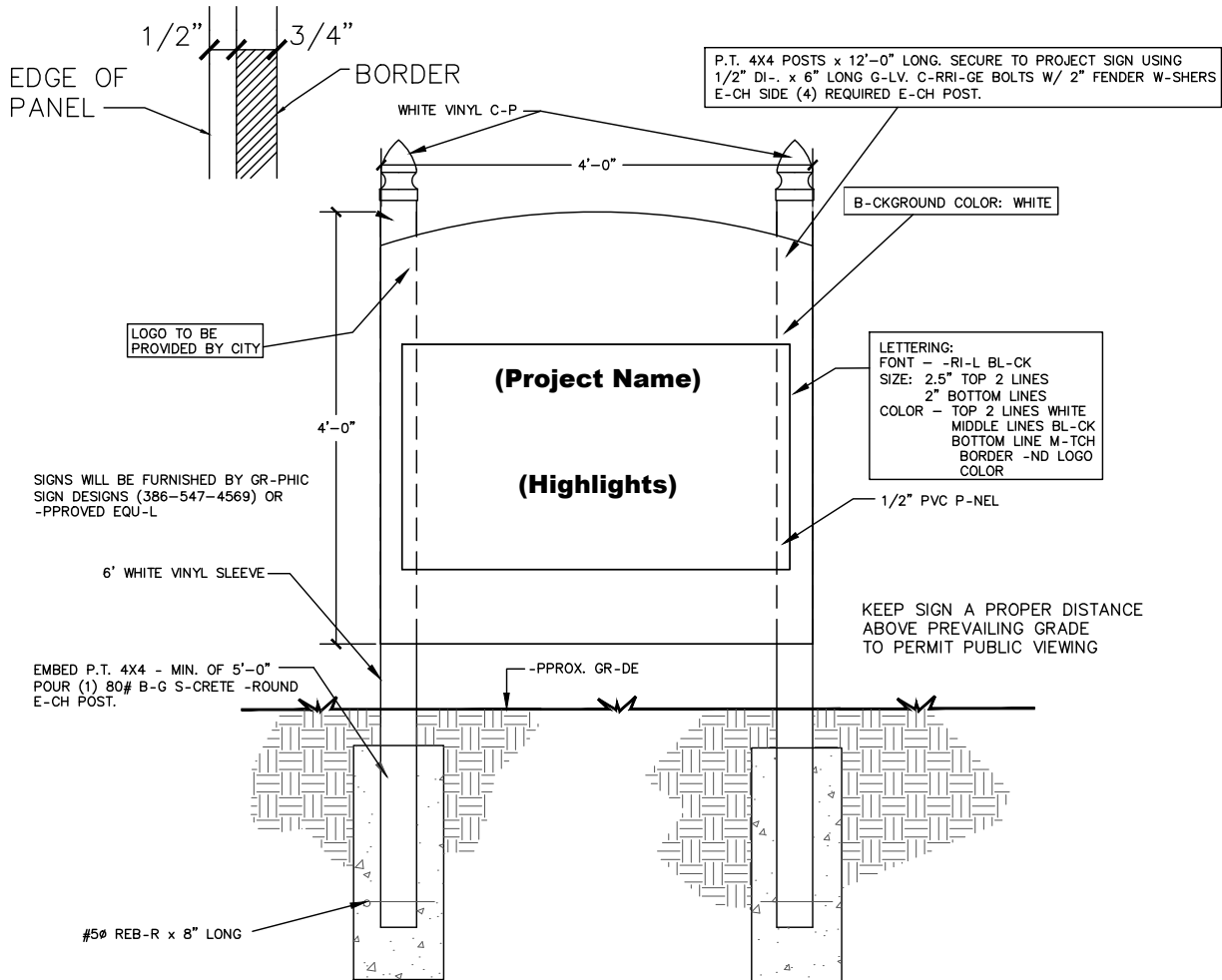

PROJECT NAME: \_\_\_\_\_

HIGHLIGHTS: \_\_\_\_\_  
 \_\_\_\_\_  
 \_\_\_\_\_



STANDARD CONSTRUCTION DETAIL  
 CIP CONSTRUCTION SIGN  
 NTS.

INDEX  
 M-19  
 March 2022

## OUTSIDE AGENCY PERMIT CHECK LIST

IN ORDER TO ENSURE THAT ALL WORK WITHIN THE CITY IS CONSTRUCTED IN ACCORDANCE WITH ALL RELEVANT FEDERAL, STATE AND COUNTY REGULATIONS, IN ADDITION TO THE CITY REGULATIONS, THE APPLICANT SHALL CHECK ALL OUTSIDE AGENCY PERMITS REQUIRED FOR THIS PROJECT ON THE LIST BELOW.

THIS LIST WILL ALSO BE USED BY CITY PERSONNEL TO VERIFY THAT TWO HARD COPIES AND ONE PDF OF ALL REQUIRED PERMITS ARE SUBMITTED TO THE PLANNING AND PERMITTING DEPARTMENT.

- 1 [ ] SJRWMD ENVIRONMENTAL RESOURCE PERMIT (ERP)
- 2 [ ] DEP WASTEWATER CONSTRUCTION/CONNECTION PERMIT
- 3 [ ] DEP WATER CONSTRUCTION/CONNECTION PERMIT
- 4 [ ] FDOT UTILITY PERMIT
- 5 [ ] FDOT DRIVEWAY CONNECTION PERMIT
- 6 [ ] COUNTY USE PERMIT
- 7 [ ] FDOT DRAINAGE CONNECTION PERMIT
- 8 [ ] DEP NPDES NOI
- 9 [ ] OTHER (PLEASE SPECIFY)



STANDARD CONSTRUCTION DETAIL  
OUTSIDE AGENCY PERMIT CHECK LIST  
NTS.

INDEX

M-20

March 2022



**GENERAL NOTES:**

1. WET WELL SHALL BE LINED WITH "RAVEN LINER" OR SEWPERCOAT CONCRETE PROTECTIVE LINER OR APPROVED EQUAL. WET WELL EXTERIOR SHALL BE COATED WITH COAL TAR EPOXY.
2. BASE AND FIRST RISER UNIT TO BE CAST MONOLITHIC.
3. ALL LOCATIONS WHERE PIPES ENTER OR LEAVE THE WET WELL SHALL BE MADE WATERTIGHT WITH WALL SLEEVE OR NON-SHRINK GROUT.
4. PUMP LIFTING DEVICE SHALL BE 304 SS LIFTING CABLE.
5. THERE SHALL BE NO ELECTRICAL JUNCTION BOXES IN WET WELL.
6. CHECK VALVES SHALL BE OUTSIDE WEIGHT & LEVER.
7. WET WELL COVER SHALL BE ALUMINUM WITH 304S.S HARDWARE, AS RECOMMENDED AND REQUIRED BY PUMP MANUFACTURER (LOADING 300 P.S.F.) AND PROVIDED WITH RECESSED LOCKS.
8. CONTROL PANEL SHALL BE AS MANUFACTURED BY THE PUMP SUPPLIER OR APPROVED EQUAL.
9. WET WELL DIAMETER SHALL BE 6' NOMINAL.
10. ACCESS HATCH DIMENSIONS ARE APPROXIMATE. CONTRACTOR SHALL COORDINATE PUMPING EQUIPMENT, PIPING AND CONCRETE STRUCTURES TO ENSURE ADEQUATE ACCESS OPENINGS FOR INSTALLATION, OPERATION AND MAINTENANCE OF ALL EQUIPMENT.
11. FURNISH AND INSTALL GENERATOR RECEPTACLE COMPATIBLE WITH CITY OF BUNNELL EQUIPMENT.
12. PROVIDE LOCKS KEYED TO THE CITY'S MASTER KEY.
13. CHAIN LINK FENCE SHALL BE CONSTRUCTED IN ACCORDANCE WITH THE FOLLOWING REQUIREMENTS:
  - A) POSTS SHALL BE SCHEDULE 40, GALVANIZED STEEL (2" OUTSIDE DIAMETER MIN.), MAXIMUM 10 FOOT SPACING
  - B) FABRIC FOR FENCING AND GATES SHALL BE 9 GAUGE 2" MESH, CLASS 1, CONFORMING TO A.S.T.M. A-392D, 1.2 OZ. GALVANIZED COATING.
  - C) POSTS SHALL BE SET IN 3000 PSI CONCRETE IN AN 8" DIAMETER HOLE WITH A DEPTH OF 36 INCHES.
  - D) FENCING SHALL BE SCREENED WITH PVC SLATS, WINGED-SLATS OR APPROVED EQUAL. COLOR SHALL BE BLACK.
14. ALARM FLOAT ON SEPARATE POWER CONTROL CIRCUIT
15. WET WELLS SHALL BE PRECAST CONCRETE. SUBMIT SHOP DRAWINGS WITH REINFORCING DETAILS FOR APPROVAL PRIOR TO FABRICATION.

**CITY OF BUNNELL LIFT STATION REQUIREMENTS:**

1. AUXILIARY POWER CONNECTION IN ACCORDANCE WITH FDEP REQUIREMENTS
2. PUMP STATION MUST HAVE ACCESS AT ALL TIMES FOR CITY MAINTENANCE VEHICLES.
3. HAND - (ON-OFF) - AUTOMATIC SWITCHES ON ALL PUMPS.
4. MANUAL - (ON-OFF) - SWITCH ON ALL ALTERNATORS.
5. ONE ELAPSED TIME METER FOR EACH PUMP.
6. 120 VOLT RECEPTACLE INSIDE CONTROL BOX.
7. 3 PHASE CURRENT (WILL NOT ACCEPT ADD A PHASE OR CAPACITOR PHASE CHANGERS).
8. ALIGNMENT ON GUIDE PIPES (NOT TOUCHING PUMP GUIDE WHEN PUMP IS SEATED).
9. POWER CABLE TO PUMPS RUN IN CONDUIT SEPARATE FROM FLOAT SWITCH CONDUIT.
10. LIQUID FILLED PRESSURE GAUGE ON FORCE MAIN.
11. THE CITY WILL NOT ACCEPT 120 VOLT TO FLOAT SWITCHES, AND MUST BE TRANSFORMER ISOLATED-24 VOLT MAX. ALL CONNECTIONS MUST TERMINATE IN CONTROL PANEL OUTSIDE OF WET WELL.
12. AS-BUILTS ON UNDERGROUND POWER SERVICE IF NOT INSTALLED BY F.P.& L.
13. MUST HAVE APPROVED LIFT STATION MANUALS, SHOP DRAWINGS, ETC.
14. KNIFE SWITCH DISCONNECT BETWEEN F.P.& L. AND LIFT STATION CONTROL PANEL.
15. LIGHTS TO BE FPL STANDARD, HEIGHT TO BE DETERMINED BY THE CITY
16. SEAL GRAVITY PIPE AT WETWELL WITH RUBBER BOOT SEAL.
17. ELECTRICAL CONTROL PANEL TO BE PROVIDED WITH A LEVEL MONITORING ACCESS PORT AND CONDUIT TO WET WELL FOR FUTURE SCADA.
18. ANY AND ALL STEEL AND/OR METAL COMPONENTS INTERNAL TO THE WET WELL SHALL BE 316 STAINLESS STEEL.
19. DEMARCATION BOX TO BE MOUNTED BY ITSELF AS SHOWN OR MOUNTED BEHIND CONTROL PANEL. UNDER NO CIRCUMSTANCES CAN DEMARCATION BOX BE MOUNTED BELOW CONTROL PANEL. DEMARCATION BOX MUST BE VENTED TO ATMOSPHERE WITH BUG SCREENS AS REQUIRED.

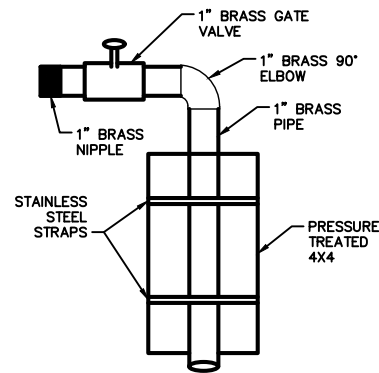

**1" WATER SERVICE DETAIL**  
N.T.S.

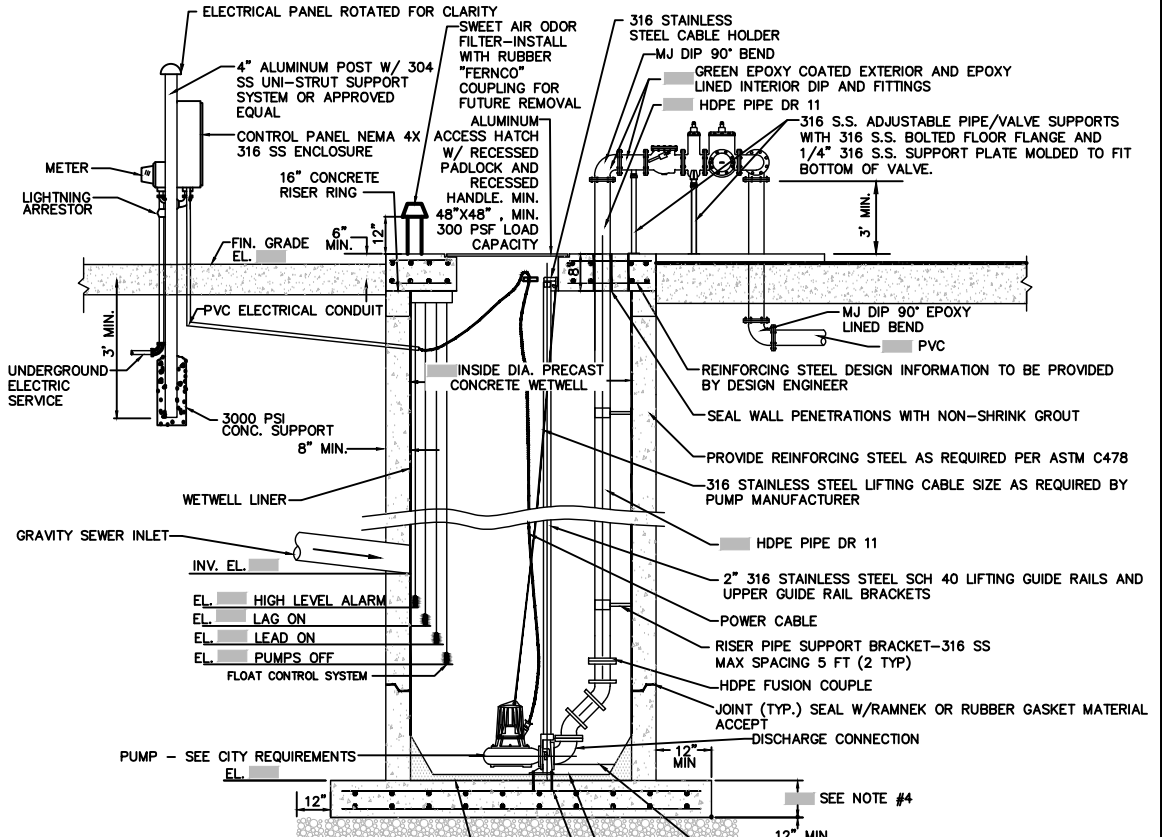
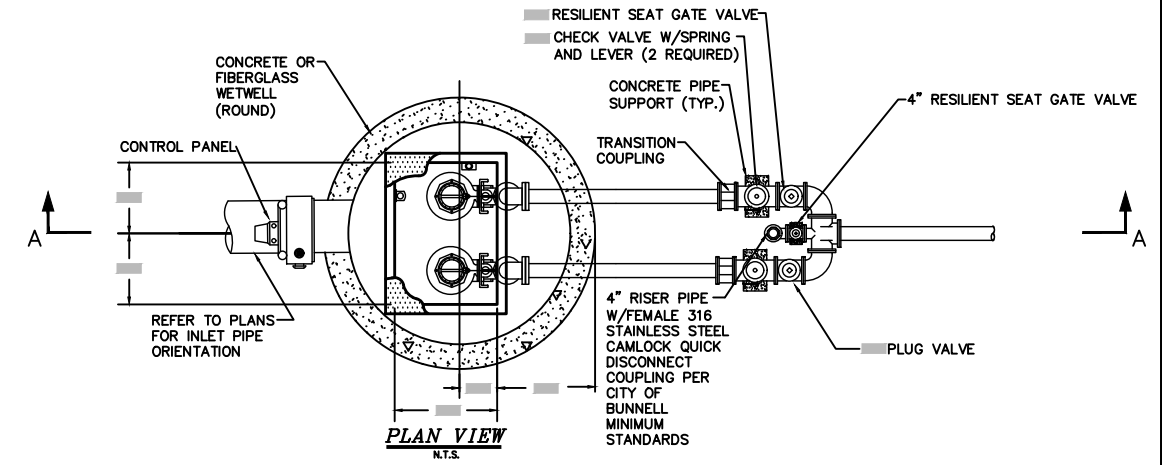

PUMP DATA AND DESIGN CHARACTERISTICS	
NUMBER OF PUMPS	
DESIGN CAPACITY PER PUMP, G.P.M.	
TOTAL DYNAMIC HEAD, FT.	
MIN. EFF. AT DESIGN CAPACITY, %	
DESIGN SPEED, MAX R.P.M.	
MAX. HORSEPOWER PER PUMP, H.P.	
MIN. SHUTOFF HEAD, FT.	
MIN. SIZE SOLIDS, IN.	
MIN. DISCHARGE SIZE, IN.	
SECONDARY CAPACITY PER PUMP, G.P.M.	
SECONDARY HEAD, FT.	
PUMP MANUF. & MODEL NUMBER	
IMPELLER DIAMETER	
PUMP R.P.M.	
ELECT. SVC. - VOLTAGE & PHASE	

**NOTE TO DESIGN ENGINEER:**

1. SHADED BOXES ( ) INDICATE INFORMATION REQUIRED TO BE PROVIDED BY DESIGN ENGINEER (e.g., ELEVATIONS, DIMENSIONS OR PIPE SIZES).
2. ENGINEER IS REQUIRED TO SHOW UNDERGROUND PIPING ARRANGEMENT (SANITARY, F.M., WATER) IN THE SITE PLAN.
3. MINIMUM SITE DIMENSION IS 30' X 30' FOR FENCE AREA.
4. BOTTOM SLAB THICKNESS SHALL BE A MINIMUM OF 18" FOR THE WETWELL. ENGINEER TO VERIFY IF ADDITIONAL THICKNESS IS REQUIRED FOR ANTI-FLOTATION BALLAST.
5. STORAGE VOLUME BETWEEN "LEAD ON" AND "PUMPS OFF" ELEVATION SHALL EQUAL OR EXCEED THE VOLUME ONE PUMP CAN DISCHARGE IN THREE MINUTES WITH NO FLOW ENTERING THE WETWELL. LOW WATER LEVEL SHALL BE SET AS RECOMMENDED BY THE PUMP MANUFACTURER TO PROVIDE ADEQUATE COOLING OF THE MOTOR AND TO PREVENT VORTEXING AND CAVITATION FROM OCCURRING.

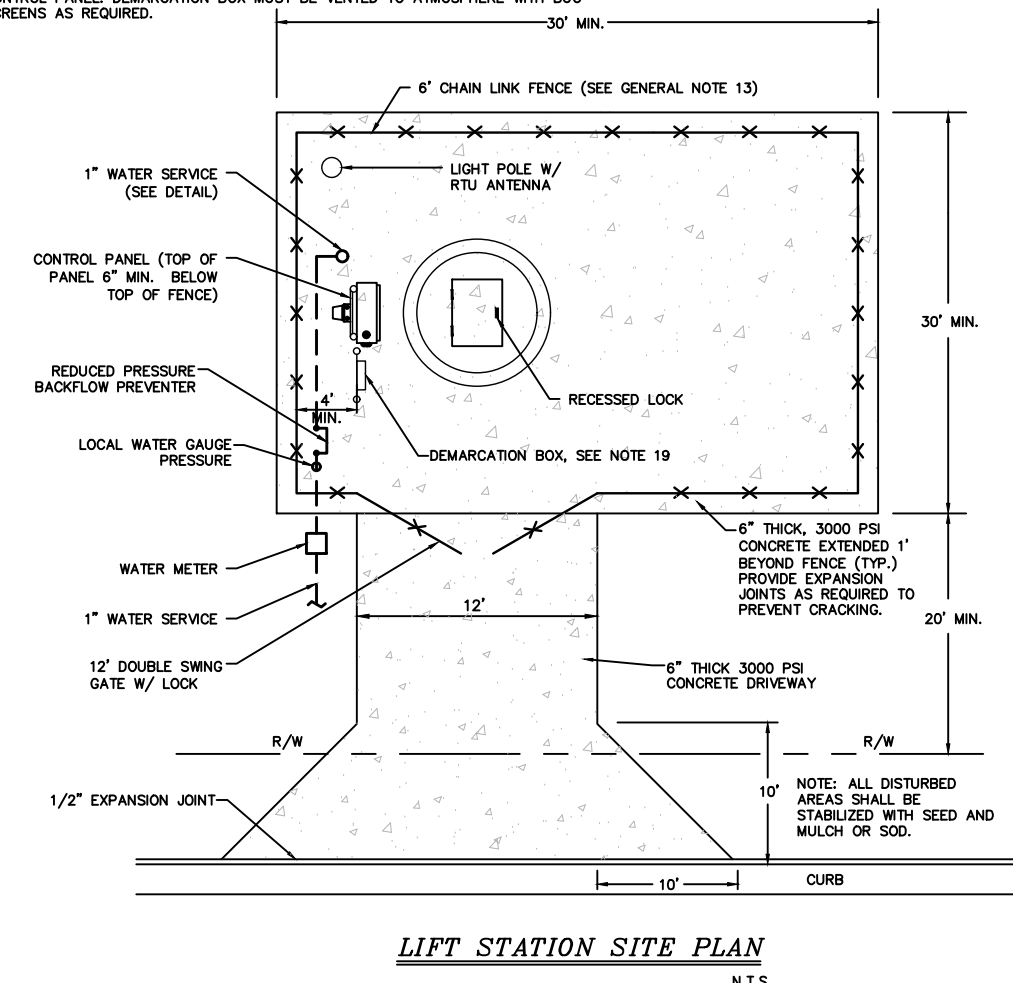
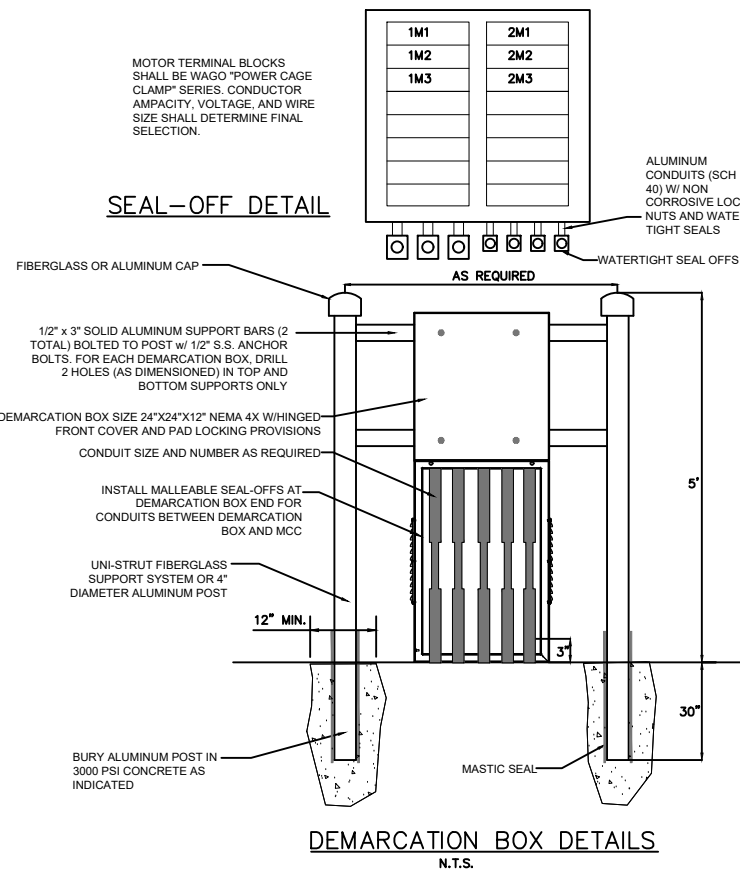

**SEWAGE LIFT STATION DETAILS**  
N.T.S.



**INDEX**

**SLS-1**

**MARCH 2022**